

DATE: October 4, 2023
TO: ALL PLAN HOLDERS
PROJECT: Burnet Municipal Airport Kate Craddock Field
Box Hangar and Associated Improvements

ADDENDUM NO. 3

The Contract Documents, Technical Specifications, and Plans for the above listed project(s) are hereby modified as follows:

0. **REMINDER: BIDDER QUESTIONS CAN BE POSTED AND ANSWERS FROM THE ENGINEER CAN BE VIEWED ON CIVCASTUSA.COM.**

0. **REMINDER: THE BID OPENING DATE WAS REVISED VIA ADDENDUM 2 TO NOVEMBER 2, 2023.**

1. Clarification: Permits, Inspections, and Fees

The Contractor is required to obtain all necessary construction permits and inspections from the City. The Contractor will NOT be required to pay the City for permit and inspection fees; however, any management, administrative, and coordination costs the Contractor may incur are not a separate pay item, will not be directly reimbursed by the City, and are considered subsidiary to the overall project cost.

2. Clarification: Water for Construction

a. Water use during construction will be at no charge to the Contractor; however, the Contractor is required to obtain a hydrant meter from the City.

3. Clarification: Electric Service

b. The Contractor is responsible for providing a conduit from the electric pole to the building in addition to setting up the meter can on the building. The City will pay for the cost of installing the transformer, the run wire, and placing the electric meter.

4. Plan Sheets

Foundation design drawings are issued via this addendum, Sheets S1.01 and S2.01. These drawings include foundation plans, notes, sections, and details. All references in the Plans and Technical Specifications requiring the Contractor to provide a sealed foundation design are hereby deleted and no longer required. All materials, equipment, and labor required to construct the foundation remains subsidiary to Pay Item 3.02.

Please note that this addendum MUST be acknowledged in the Bid Form where indicated on Page 1.

**ADDENDUM NO. 3 ISSUED BY:
KSA ENGINEERS, INC.**

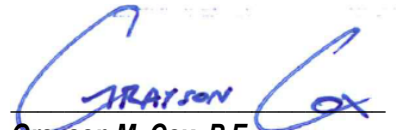

**Grayson M. Cox, P.E.
Project Manager**

Enclosed:

- Foundation Design Drawings, Sheets S1.01 and S2.01, sealed September 21, 2023

J:\JOBS\2023\2351 KSA - BURNETT HANGAR\STRUCTURAL\DWG\ S1.01 18/21/2023 - 2:51 PM - LAST SAVED BY: SHANNON MCCOWN

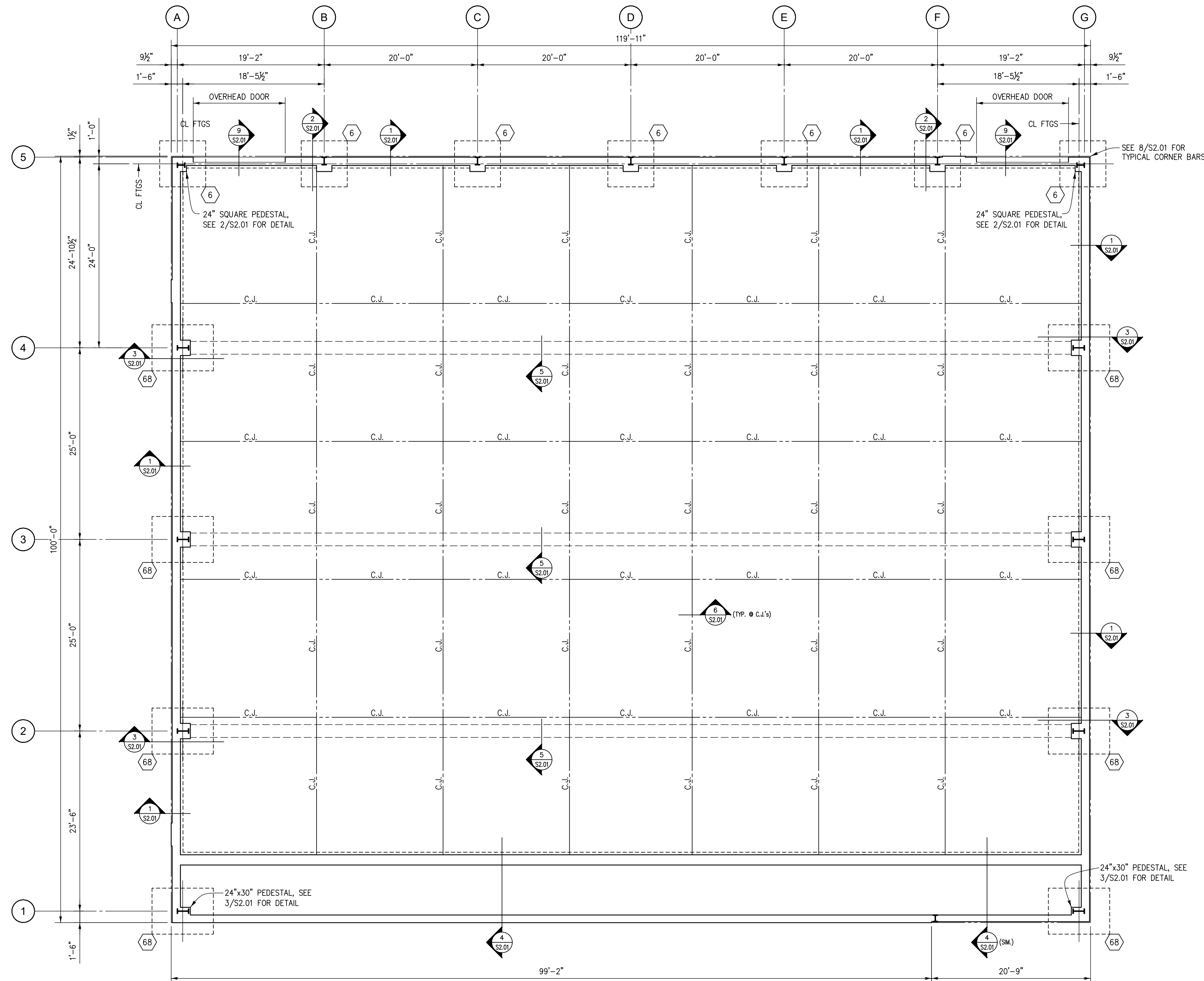

SHEET NOTES (SN):

- HANGAR SLAB ON GRADE: 8" CONCRETE (5,000 PSI) SLAB w/ #5 @ 16" O.C. EACH WAY ON VAPOR BARRIER ON 4" CRUSHED AGGREGATE BASE (MEETING THE REQUIREMENTS OF ITEM 247, FLEXIBLE BASE, TYPE D, GRADE 1-2 IN THE TXDOT STANDARD SPECIFICATIONS FOR CONSTRUCTION OF HIGHWAYS, STREETS AND BRIDGES) ON PREPARED SUBGRADE (NOTE: CHOKE OFF CRUSHED AGGREGATE BASE WITH SAND TO PROVIDE A SMOOTH SURFACE ALLOWING SLAB TO SHRINK AND SWELL).
- SPREAD FOOTING SIZES AND LOCATIONS ARE BASED ON ASSUMED COLUMN REACTIONS AND LAYOUT. SPREAD FOOTINGS ARE SUBJECT TO CHANGE PENDING METAL BUILDING DESIGN. THEREFORE, THESE ITEMS SHALL NOT BE INSTALLED UNTIL A BUILDING DESIGN HAS BEEN SUBMITTED BY THE BUILDING MANUFACTURER AND THE FOUNDATION DESIGN HAS BEEN VERIFIED AND/OR REVISED BY THE STRUCTURAL ENGINEER OF RECORD.

FINISH FLOOR EL. (FFE) = 100'-0"

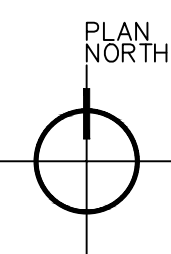

FOUNDATION PLAN

SCALE: 1/8"=1'-0"

GENERAL NOTES:

- The Contractor shall verify field dimensions and conditions before construction and notify the Architect of any discrepancies or inconsistencies before proceeding with the work.
- The Contractor shall verify locations and sizes of all openings in floors and roofs and all inserts and embedded items with mechanical, electrical, and architectural drawings before placing concrete, installing decking or erecting any structural load bearing material. The general contractor shall be solely responsible for all coordination with sub-contractors.
- Adequate temporary bracing will be required of all structural pieces or units until all walls and/or floor or roof decks are in place, and all concrete has gained its ultimate strength.
- In case of discrepancies and elevations between structural and architectural drawings, the contractor shall verify with the Architect prior to fabrication and construction.
- Vapor barrier below slab-on-grade shall be 15 mil. by Stego Industries. Lap splice all joints 6 inches and seal with manufacturer's tape. Seal all pipe, conduit, etc., penetrations with manufacturer's tape. Seal all tears and punctures prior to placing concrete.
- The latest edition of ACI, AISI, AWS, and CRSI specifications shall govern all phases of fabrication and construction.

REINFORCING STEEL NOTES:

- All reinforcing steel shall be new billet, ASTM A615 grade 60 deformed domestic bars. All detailing, fabrication, placing, and supporting shall be in accordance with ACI 318 and CRSI.
- All dowels shall be the same size and spacing as adjoining main bars with a Class B lap splice, minimum unless noted or detailed otherwise. Splice all continuous bars with a Class B lap splice, minimum unless noted or detailed otherwise.
- Clear minimum coverage of concrete over reinforcing bars shall be as follows unless noted or detailed otherwise:
 concrete placed against earth..... 3 inches
 formed concrete against earth..... 2 inches
 beams to ties/stirrups..... 1 1/2 inches
 top and bottom of suspended slabs..... 3/4 inches or bar dia.
- All reinforcing bars, W.W.F., bolts, dowels, inserts, etc., shall be rigidly secured in position prior to placing concrete.
- Contractor shall submit complete shop and placing drawings and obtain approval prior to fabrication.

FOUNDATION NOTES:

- Foundation design is based on the soil investigation by MLA Geotechnical Engineering and Construction Materials Testing, Job #22106100.004. All subgrade preparation, fill installation, and foundation installation shall be in strict accordance with the Soil Report.
- The building foundation has been designed as a shallow foundation system in accordance with Option 1 on page 7 of the soil report. Spread footings shall bear on a minimum of 12 inches of compacted select fill and have been sized for an allowable bearing capacity of 4,000 psf.
- Contractor shall provide for dewatering at excavations from either surface water or seepage. Contractor shall provide adequate shoring to prevent cave-ins.
- All foundation excavations and subgrade preparation shall be inspected by a representative of the Geotechnical Engineer prior to placement of reinforcing steel or concrete.

CONCRETE NOTES:

- The concrete supplier shall submit concrete mix design data to the Architect for review prior to construction.
- Materials shall conform with:
 Cement-ASTM C150 Type I or II
 Aggregate-ASTM C33
 Water - Potable
- Use the following table for guidance in preparing mix designs for the given type of pour:

CONCRETE MIX DESIGN PARAMETERS						
TYPE OF POUR	28 DAY COMPRESSIVE STRENGTH	MAX. WCR	MIN. CEMENT CONTENT (LBS/CY)	TARGET SLUMP	MAX. AIR CONTENT	MAX. AGGREGATE SIZE
slab on grade	5000 psi	0.48	517	4"	3%	1"
grade beams & footings	3500 psi	0.53	470	4"	4% to 7%	1"

- Proportioning of concrete mix designs shall be determined by the procedures established in Section 5.3 of ACI 318. The concrete supplier shall submit concrete mix designs to the Architect/Engineer for review and approval prior to construction.
- Flyash and other pozzolans shall conform to ASTM C-618 and shall not make up more than 20 percent of the total cementitious materials by weight. Do not use flyash in concrete when the temperature during placement or curing is projected to fall below 50° F.
- Utilities which project through the slab on grade shall be wrapped with expansion joint material or shall be set with oversized sleeves such that the utility does not hamper the ability of the slab to expand and contract.

CAST-IN-PLACE CONCRETE EXECUTION NOTES:

- All concrete is reinforced unless specifically noted as 'unreinforced'. Reinforce all concrete not otherwise shown with the same steel as shown in similar sections. Comply with ACI 304, Recommended Practice for Measuring, Mixing, Transporting, and Placing Concrete.
- Cold weather conditions: When air temperature has fallen to or is expected to fall below 40 deg. F, all concrete placement shall comply with the provisions of ACI 306 and as herein specified. Protect concrete work from physical damage or reduced strength that could be caused by frost, freezing actions, or low temperatures.
- Hot weather conditions: When air temperature exceeds 90 deg. F, all concrete shall comply with the provisions of ACI 305 and as herein specified.
- Perform curing of concrete by curing and sealing compound, by moist curing, moisture-retaining cover curing, or by combinations thereof.
- Coordinate concrete finishes, recessed areas, reveals, embedded items, special joint patterns, etc. with the Architectural drawings and specifications. No aluminum items shall be embedded in concrete.
- All openings in concrete slabs shall be reinforced with (1) #3 rebar (opening dimension plus 2 feet each side) along each side of opening, and (1) #3 x 48 inches diagonally at each corner. Reinforce all re-entrant corners with (1) #3 x 48 inches diagonally. Add additional steel to match above for each layer of steel shown.

MARK	REVISION	DATE

FOUNDATION PLAN AND NOTES

**CITY OF BURNETT, TEXAS
BURNETT MUNICIPAL AIRPORT
BOX HANGAR AND
ASSOCIATED IMPROVEMENTS
BURNETT, TEXAS**

DRAWN BY: SDM	DESIGNED BY: SDM	LATEST REVISION: -	KSA JOB NO.: 100300
------------------	---------------------	-----------------------	------------------------

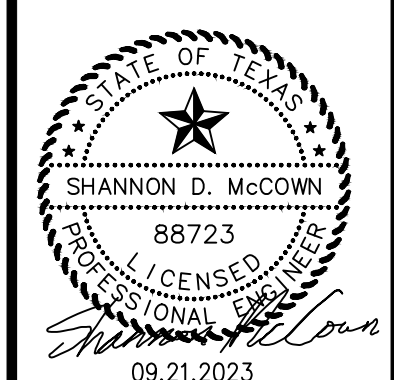

SEAL: Shannon McCown
 TBPE Firm Registration No. F-9224
 SHEET NO.

S1.01

MARK	REVISION	DATE

FOUNDATION SECTIONS AND DETAILS

**CITY OF BURNETT, TEXAS
BURNETT MUNICIPAL AIRPORT
BOX HANGAR AND
ASSOCIATED IMPROVEMENTS
BURNETT, TEXAS**

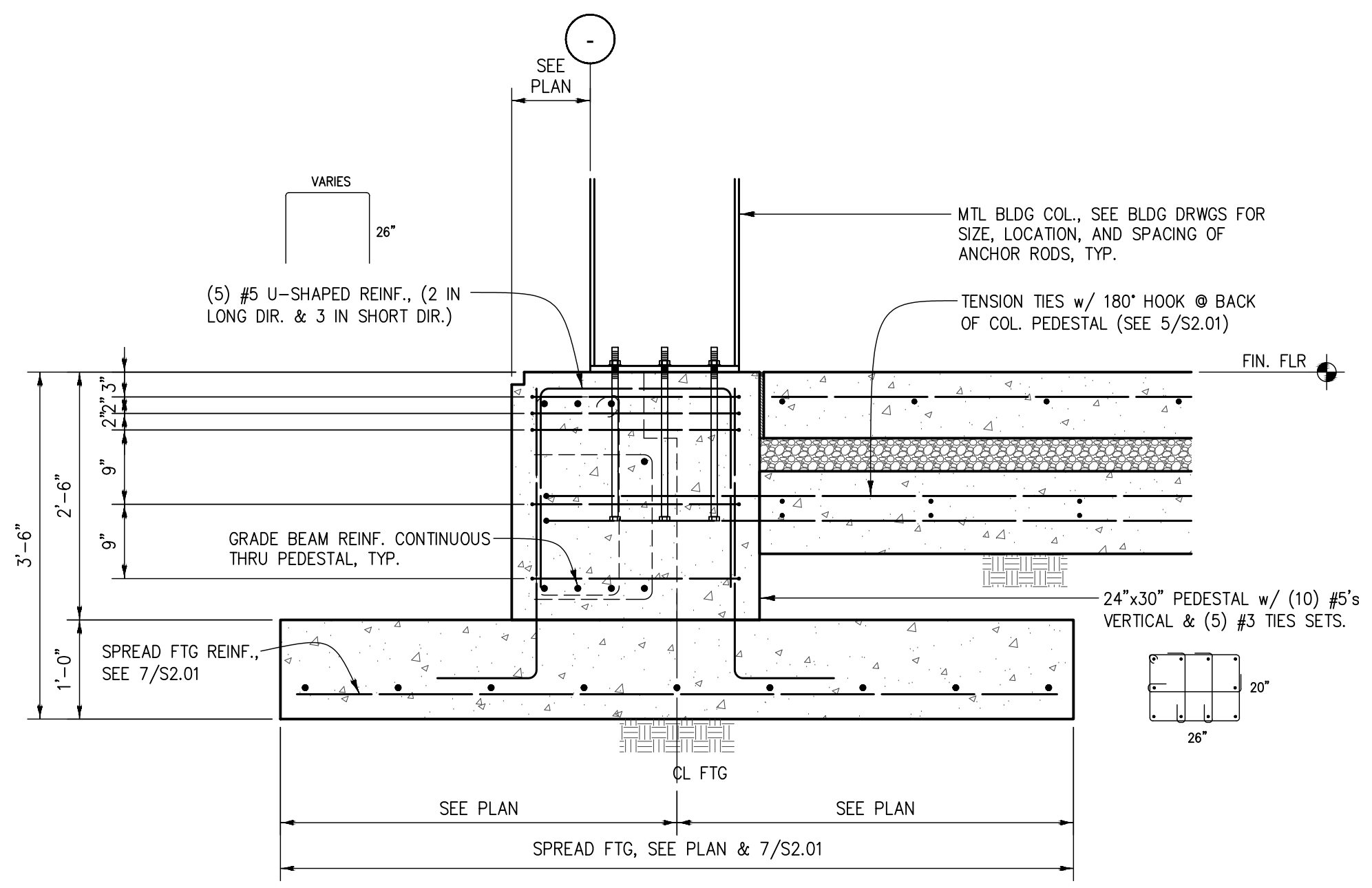

Ø	EMBEDMENT
1/2" & 3/8"	12"
3/4"	15"
7/8" & 1"	18"

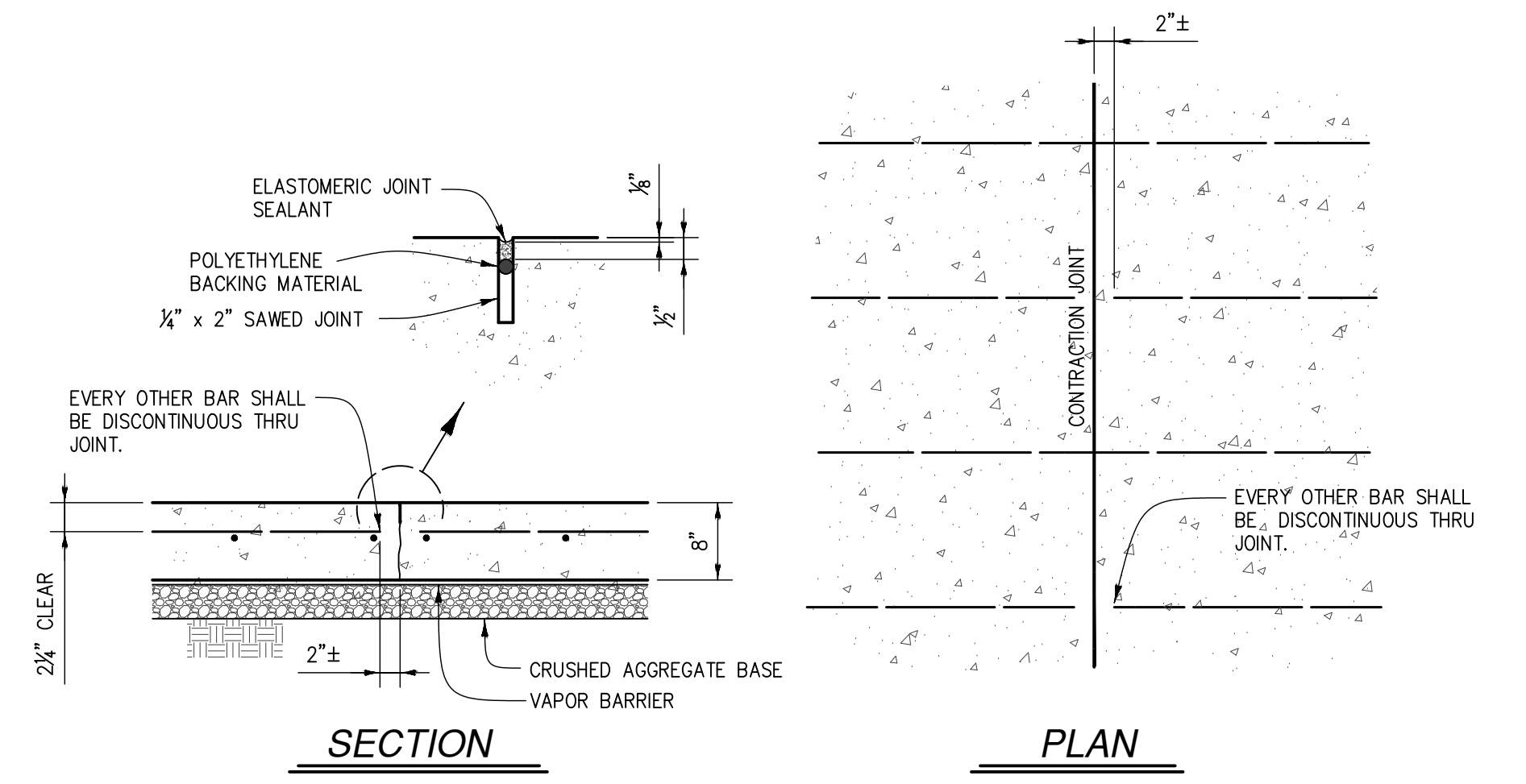
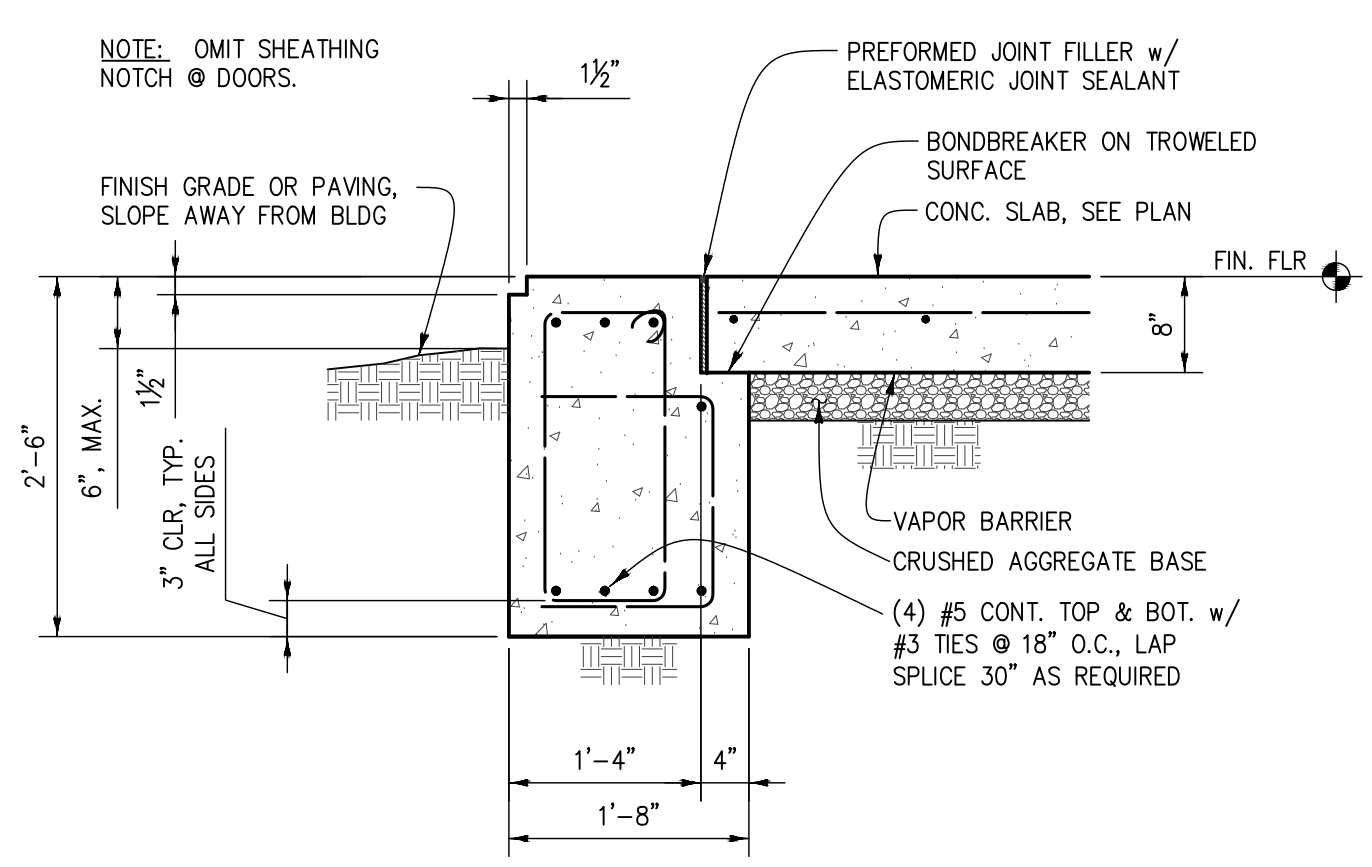
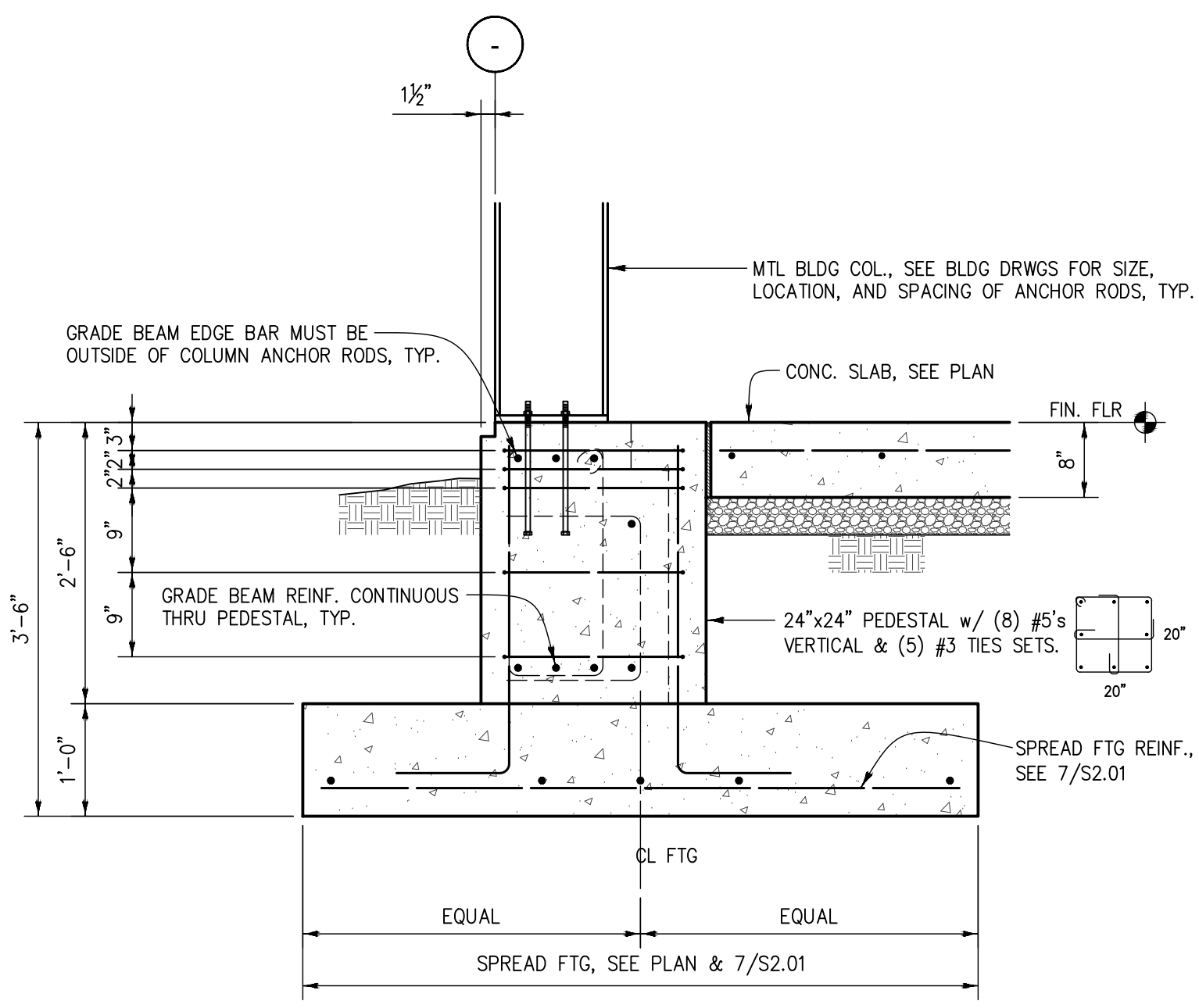

NOTES:
 1. SAWED JOINTS SHOULD BE CUT 4 TO 12 HOURS AFTER THE SLAB HAS BEEN FINISHED IN AN AREA - 4 HOURS IN HOT WEATHER AND 12 HOURS IN COLD WEATHER.
 2. ALL SUBGRADE RUTTING SHALL BE REPAIRED PRIOR TO SLAB PLACEMENT.

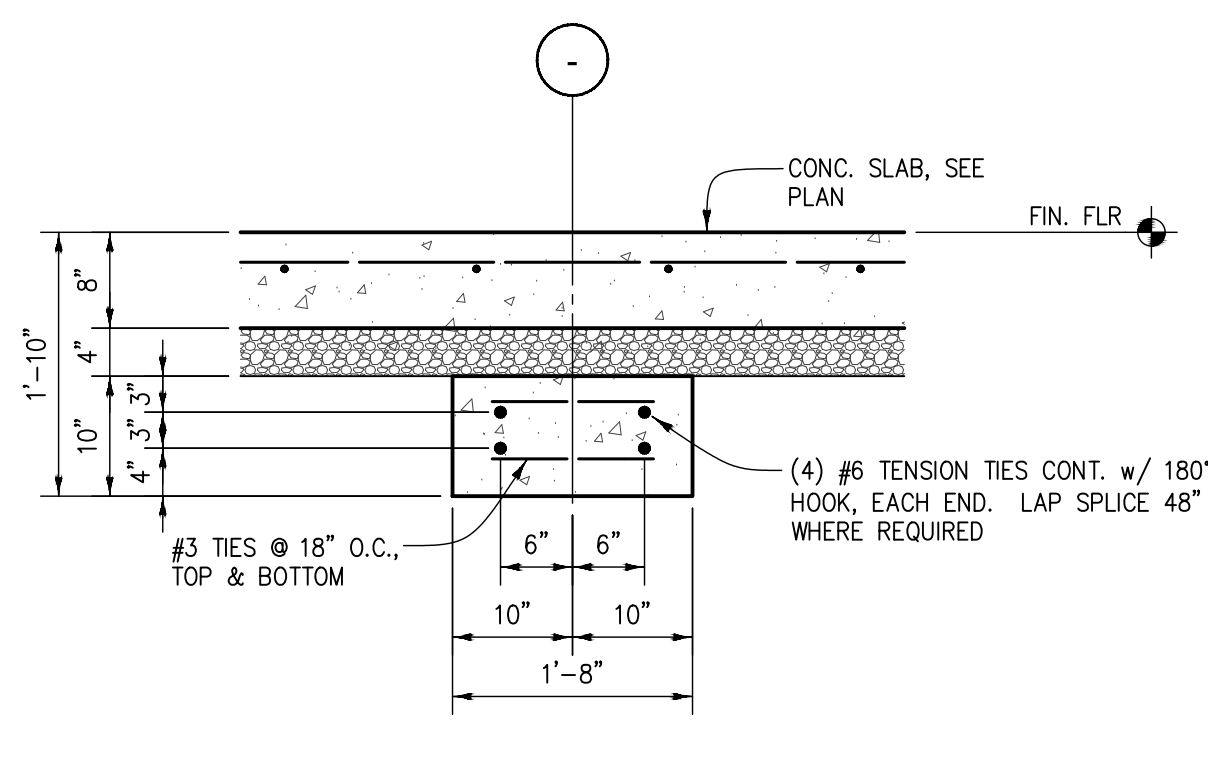
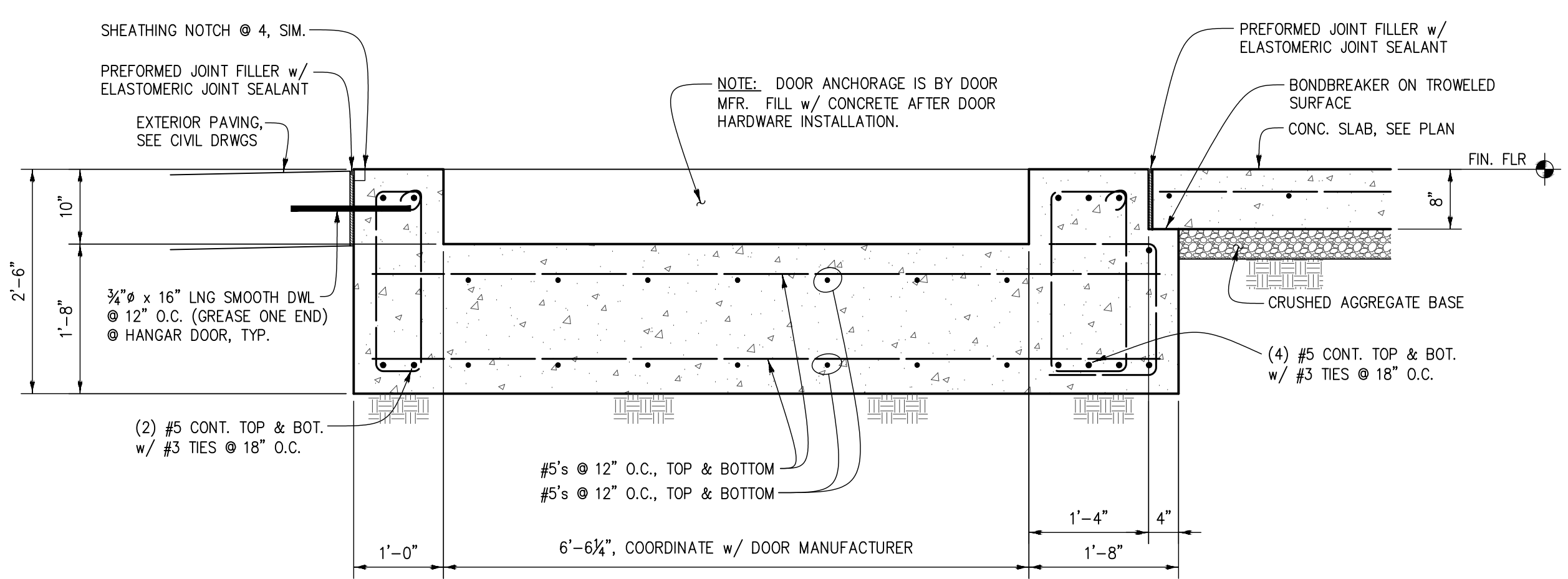

SLAB-ON-GRADE CONTRACTION JOINT (C.J.) DETAIL - 8" SLAB SCALE: 3/4"=1'-0" S2.01

SECTION SCALE: 3/4"=1'-0" S2.01

SECTION SCALE: 3/4"=1'-0" S2.01

MARK	SIZE	T	REINFORCING	REMARKS
6	6'-0" x 6'-0"	1'-0"	(7) #5 EACH WAY, BOTTOM	
68	6'-0" x 8'-0"	1'-0"	(7) #5 IN SHORT DIR., BOTTOM (9) #5 IN LONG DIR., BOTTOM	

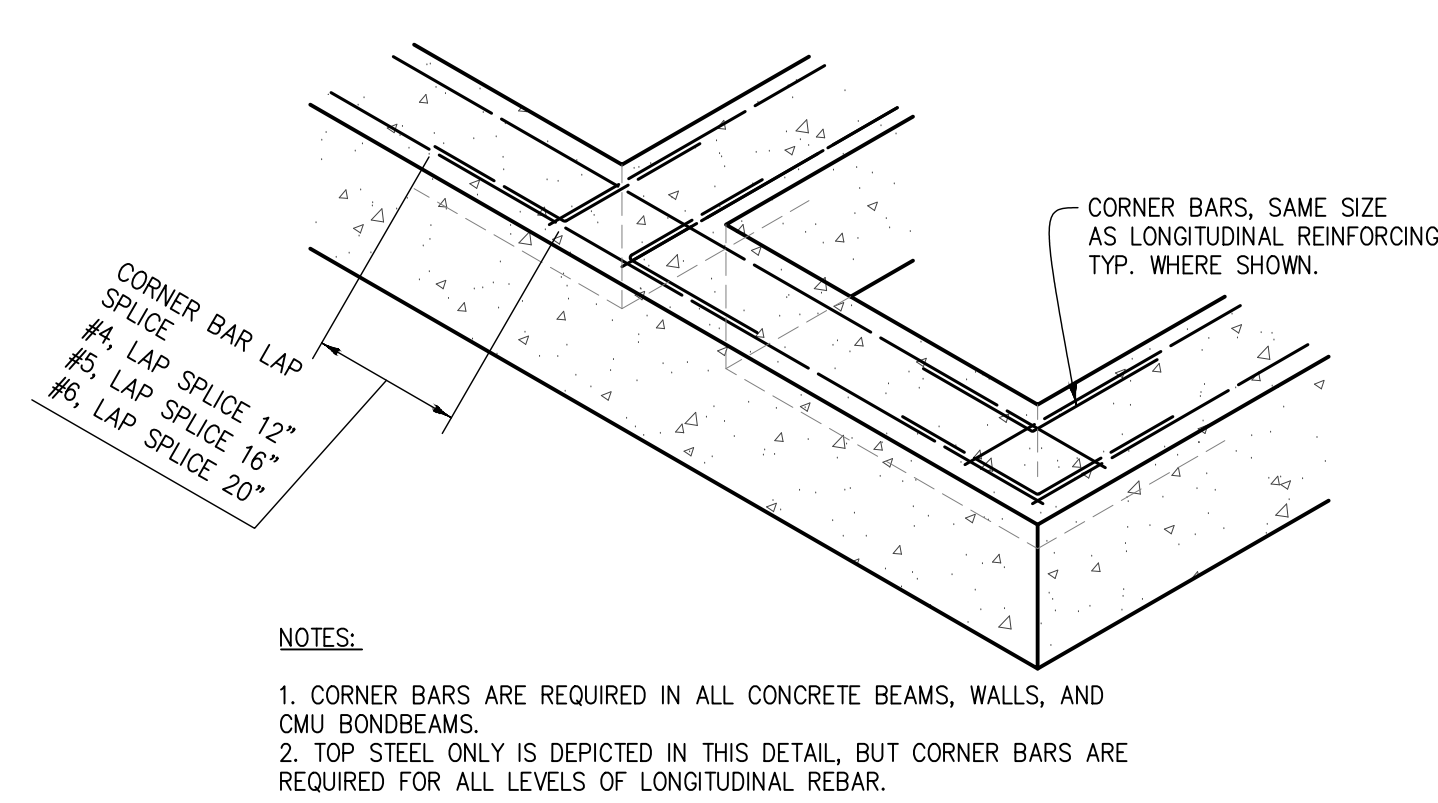

NOTES:
 1. CORNER BARS ARE REQUIRED IN ALL CONCRETE BEAMS, WALLS, AND CMU BOND BEAMS.
 2. TOP STEEL ONLY IS DEPICTED IN THIS DETAIL, BUT CORNER BARS ARE REQUIRED FOR ALL LEVELS OF LONGITUDINAL REBAR.

SPREAD FOOTING SCHEDULE SCALE: 3/4"=1'-0" S2.01

CORNER BAR DETAIL SCALE: N.T.S. S2.01

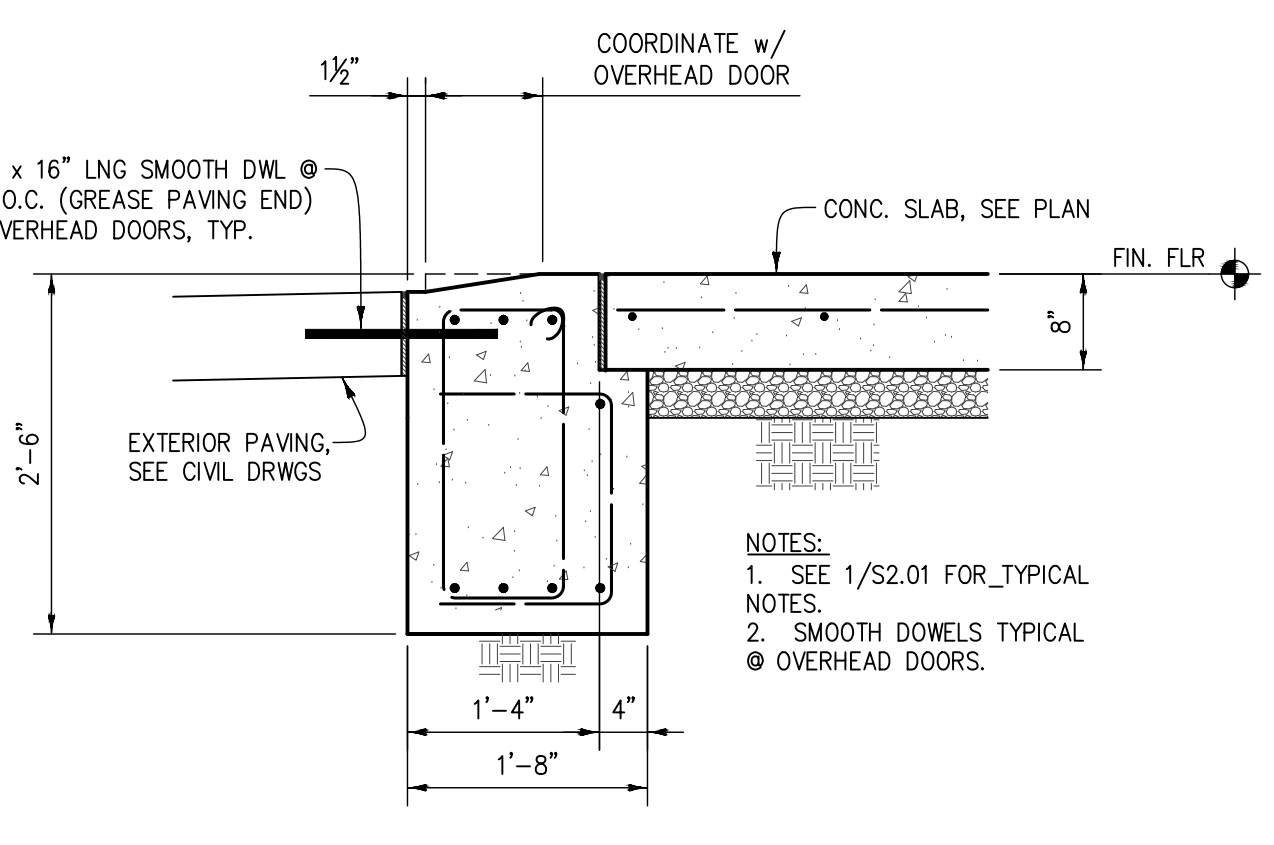

NOTES:
 1. SEE 1/S2.01 FOR TYPICAL NOTES.
 2. SMOOTH DOWELS TYPICAL @ OVERHEAD DOORS.

SECTION SCALE: 3/4"=1'-0" S2.01