



City of Burnet

Developers Underground Developers Specifications

Date: February 22, 2022

Underground Specification

**Developer/Applicant
Supplied Material**

**Date: Feb. 22, 2022
Specification Number: 500-100**

Developers Underground Utility Specifications Index

Page #	Specification/ Drawing No.	Drawing No.	Description
3	500-100	-	Developer/Applicant Supplied Material
4	500-100	-	Developer/Applicant Supplied Material
5	500-100	-	Developer/Applicant Supplied Material
6	500-100	-	Developer/Applicant Supplied Material
7	510-010	E-01	Single Phase Conduit Arrangement for Primary Only
8	510-012	E-02	Single-Phase Conduit Arrangement Primary and Secondary Only
9	510-014	E-03	Typical Conduit Arrangement Joint Trench with Telecommunication and/or Secondary
10	510-016	E-04	Single-Phase Conduit Arrangement for Secondary
11	510-020	E-05	Three-Phase Conduit Arrangement for Secondary
12	510-024	-	Conduit Crossing Detail
13	510-027	E-07	Conduit Installation on a slope of greater than 4:1 with Concrete Cap
14	510-028	E-08	Conduit Installation in Flood Prone areas
15	520-010	E-09	Typical Pad for Single or Multiple Service Meter Pedestal
16	520-030	E-10	Typical Pad for Single-Phase Transformer, Single-Phase Transformer with VFI, or Small Sectionalizing Enclosure
17	530-000	-	Poured in place vault specifications
18	530-020	-	Small Pad for Three Phase Sectionalizing Enclosure
19	530-022	-	Large Pad for Three Phase Sectionalizing Enclosure
20	530-030	-	Three Phase Transformer Pad 45 - 500kVA
21	530-032	-	Three Phase Transformer Pad 750 - 1500kVA
22	530-034	-	Three Phase Transformer Pad 2000 - 3000kVA
23	530-050	-	Vault for Submersible Switchgear & Splice Box (3D Drawing)
24	530-051	-	Lid for Submersible Switchgear & Splice Box (for use on Vault 530-050)
25	530-060	-	Vault for Combination Lid and 750kVA and Larger Transformers
26	530-061	-	Combination Lid (for use on Vault 530-060)
27	530-065	-	Lid for 750-3000kVA Three-Phase Transformer (for use on Vault 530-060)
28	530-080	-	Vault for 56 and 74 Enclosure, Single-Phase Transformers, and Three-Phase 45-500kVA Transformers
29	530-081	-	Lid for 56 & 74 Enclosures (for use on Vault 530-080)
30	530-085	-	Single-Phase Transformer Lid (for use on Vault 530-080)
31	530-086	-	45-500kVA Three-Phase Transformer Lid (for use on Vault 530-080)
32	530-090	-	Vault for Switchgears
33	530-091	-	Lid for Switchgear
34	550-010	-	Secondary Enclosure
35	560-010	-	Single-Phase Riser Wood Pole
36	560-015	-	Single-Phase Riser Metal Pole using Standoff Brackets
37	560-020	-	Three-Phase Riser Wood Pole
38	560-025	-	Three-Phase Riser Metal Pole using Standoff Brackets
39	570-010	-	Safety Clearances around Padmount Underground Transformers
40	570-015	-	Working Clearances around Padmount Underground Transformers

Underground Specification

**Developer/Applicant
Supplied Material**

**Date: Feb. 22, 2022
Specification Number: 500-100**

1	A	Cable, primary, URD 25 kV single conductor with neutral. Supplied by City of Burnet. Developer/Applicant will be invoiced for cable at current price.
	B	
	C	
	D	
	E	
2	A	Cable, secondary. Supplied by City of Burnet. Developer/Applicant will be invoiced for cable at current price
	B	
	C	
	D	
3		Conduit 2" PVC, electrical grade Schedule 40.
4		Conduit 3" PVC, electrical grade Schedule 40.
5		Conduit 4" PVC, electrical grade Schedule 40.
6		Conduit bends, 2", 24" min. radius, electrical grade Schedule 40 (Secondary only).
7		Conduit bends, 2", 36" min. radius, electrical grade Schedule 40 (Primary)
8		Conduit bends, 3", 24" min. radius, electrical grade Schedule 40 (Secondary only).
9		Conduit bends, 3", 36" min. radius, electrical grade Schedule 40 (Primary).
10		Conduit bends, 4", 48" min. radius, electrical grade Schedule 40.
11		Bell end fitting, 2", with plug.
12		Bell end fitting, 3", with plug.
13		Bell end fitting, 4", with plug.
14		Caps for 2" conduit, 2" PVC. PLUGS NOT ACCEPTABLE where bell fittings are not used.
15		Caps for 3" conduit, 3" PVC. PLUGS NOT ACCEPTABLE where bell fittings are not used.
16		Caps for 4" conduit, 4" PVC. PLUGS NOT ACCEPTABLE where bell fittings are not used.
17		Trench -minimum of 30" cover to sub-grade. NOTE: Bottom of trench shall be sanded smooth and level. Sand to be applied over conduits for initial backfill.
18		Spacer for 2" conduit with 2" spacing:
		Base - Cantex 5335977 Intermediate- Cantex 5336018
19		Spacer for 3" conduit with 2" spacing:
		Base - Cantex 5335964 Intermediate- Cantex 5336020
20		Spacer for 4" conduit with 2" spacing:
		Base - Cantex 5335967 Intermediate- Cantex 5336019
21		Unused one-piece Polyester pulling tape to be installed in conduit- 2500 lbs. or more tensile strength, with footage markers. Neptco WP2500P
22		Red electric warning tape (linear quantity equal to trench length).

Underground Specification

**Developer/Applicant
Supplied Material**

**Date: Feb. 22, 2022
Specification Number: 500-100**

23	Sectionalizing terminal.
24a	Sectionalizing terminal, pad mount, 25k V, 3 phase to accommodate 600 amp junctions and tee connectors, or (3) 200A 4-point terminals. Cabinet and door to be 12 to 14 gauge steel. Ground clamp nuts to be welded in place. Minimum of one parking stand per phase. Terminal to be 30" high x 48" wide and 22" deep. Malton MEH304823 Shallbetter Inc. SSED-3-304822 Maysteel CW348-22TH Durham AM304822262 See drawings #530-080 and #530-081
24b	Sectionalizing terminal, pad mount, 25 kV, 3 phase too accommodate 600 amp junctions and tee connectors, or (3) 200A 4-point terminals. Cabinet and door to be 12 or 14 gauge steel. Ground clamp nuts to be welded in place. Minimum of one parking stand per phase. Terminal to be 30" high x 66" wide x 22" deep. Malton MEH306723 Shallbetter Inc. SSED-3-306622 Maysteel CW366-22TH Durham AM306622263 See drawings #530-080 and #530-081
25	Vault and lid for 48" and 66" wide sectionalizing enclosures. CDR PE20-3660-19, PE22-3660-29, PP487204-1226 Electric Vault Company V-4866 and LL-4872-H See drawings #530-080 and #530-081
26	Vault and Lid for Combination concrete pad for 48" and 66" wide sectionalizing enclosure and pad mount transformer. CDR PE20-3660-19 and PE22-3660-29 Electric Vault Company V-7296 and LC-8496-N See drawings #530-060 and #530-065
27	Vault and lid for single-phase transformer. CDR PE20-3660-19, PE22-3660-29, and PP487204-1226 Electric Vault Company V-4866 and LT -4872-H See drawings #530-080 and #530-085
28	Vault and lid for 3 phases, 45-500 kVA transformers. CDR PE20-3660-19, PE22-3660-29, and PP787804-1648. Electric Vault Company V-4866 and LT-7878-H See drawings #530-080 and #530-086
29	Vault and lid for phase, 750-3000 KVA transformer. CDR PE20-8596-19, PE22-8596-29, and PP12012004-2057. Electric Vault Company V-4866 and LT-120120-H See drawings #530-060 and #530-087
30	Vault and lid for Switchgear. CDR PE20-8596-19, PE22-8596-29, and PP969604-2x1864. Electric Vault company V-9696 and LSG-9696-H. See drawings #530-090 and #530-091
31	Vault and lid for Submersible Switchgear and Splice Box. CDR PE22-72144-40 and PC10-2436-03. Electric Vault Company V-72144846 and LT-72144-H. See drawings #530-050 and #530-056
32	Concrete pad for meter pedestal. See drawing #520-010

Underground Specification

**Developer/Applicant
Supplied Material**

**Date: Feb. 22, 2022
Specification Number: 500-100**

33	Underground secondary enclosure, to have opening of 13" x 24" and 34" min. height. Lid to have two penta-head bolts and must read "POWER" or "ELECTRIC" CDR A10-1324-18 and E10-1324-16 See drawing #550-010
34	Underground secondary enclosure, to have opening of 17" x 30" and 34" min. height. Lid to have two penta-head bolts and must read "POWER" or "ELECTRIC" CDR A10-1730-18 and E10-1730-16 See drawing #550-010
35	Ground rods, 3/4" x 10' Copper Clad Rod.
36	Ground rod clamps for 3/4" rod to accommodate #2 copper 7 strand. Penn Union CEB-3

Trench Specifications:

A. Installation of conduit

1. Minimum cover to be 30" from top of primary conduit to sub-grade. (See attached drawings.)
2. Bottom of trench shall be sanded to provide smooth, even support for conduits.
(See attached drawings.)
3. Sand to be placed directly around conduits for initial backfill. (See attached drawings.)
4. There is to be a minimum of 12" separation between electrical conduits and all other conduits.
5. Warning tape to be a minimum of 12" above electrical conduits.
6. Concrete to be poured around all conduit crossings and 90 degree bends. (See attached drawings.)
7. Trench may be used jointly if adequate separation is provided. (See attached drawings.)
8. Conduit may be under pavement if a depth of 30" cover to sub-grade is maintained.

B. Inspection Schedule

1. After primary conduit installation.
2. After initial backfill
3. After secondary conduit installation.
4. After remainder of initial backfill.
5. After secondary backfill.

Failure to receive inspection will require removal of the backfill to allow inspection.

Developer/Contractor contribution:

1. Payment to City of Burnet for materials furnished to Developer through the City of Burnet.
2. Trench
3. Conduit:
 - a. 2" conduit and accessories
 - b. 3" conduit and accessories
 - c. 4" conduit and accessories
 - d. Conduits for service will be sized as needed

NOTE: Contractor may be required to pull a mandrel, of a diameter not less than 80% of the inside diameter of the conduit, through all conduit, under the supervision of a City of Burnet representative.

4. Conduit spacers.
5. Transformer pads.
6. Meter pedestal pads.
7. Underground secondary enclosures and extensions.
8. Ground rods and clamps.
9. Pulling tape in all conduit.
10. Warning tape.
11. Sand for initial backfill.
12. 3/8" gravel for secondary backfill.
13. 1/2" to 3/4" gravel for bottom of vaults.

Underground Specification

**Developer/Applicant
Supplied Material**

**Date: Feb. 22, 2022
Specification Number: 500-100**

14. Concrete where necessary.
15. Install meter socket when metering on building.
16. Furnish and install any gang type meter sockets.
17. Primary enclosures.

Customer's Responsibility:

Meter pedestals are presently approved for use except under special circumstances designated by the City of Burnet. In situations where meter pedestals are required the following conditions will apply:

1. Purchase and install circuit breaker in box. Circuit breakers are the bolt-in type. The box will accommodate 125, 150, and 200 amp breakers. The breaker must have an interrupting capacity of 10,000 amps rated at 240 volts. GE Cat. No. TQD22 (amp needed) WL and Westing house CA2200W or equal.
2. Install insulated jumpers from bottom of meter socket to top of breakers.
3. Install galvanized rigid conduit, schedule 40 PVC or an approved equal from pedestal pad to bottom of box.
4. Customer will be responsible for the installation of underground cable from the meter pedestal to the house and the connections to the bottom of the circuit breakers. The underground cable used from the meter pedestal to the house shall be an approved type for underground installation (USE or UF type). Conductor size will be based on customer load, location of meter, and National Electric Code for size of conduit.
5. Underground conductor from secondary enclosure/transformer to meter shall be buried 24" deep. This depth may be reduced to 18" when a 2" supplemental protective covering is provided. If galvanized rigid conduit is used, the depth can be reduced to 6". Red electric warning tape is also required in the secondary ditch.
6. Apply and receive all applicable inspections.
7. When all work is completed according to specifications, notify the City of Burnet office that you are ready for electric service. A serviceman will make the connect and set the meter on a routine connect order.
8. For Commercial applications the Customer shall purchase from the City the CT & PT metering (if needed).

City of Burnet contribution:

1. Primary conductors (paid for by developer/applicant)
2. Secondary conductors (paid for by developer/applicant)
3. Cable terminations
4. Transformers up to 100kVA
5. Meter pedestals and individual meter sockets (paid for by developer/applicant)
6. Meter sockets (paid for by developer/applicant)
7. Switchgear (if applicable) (paid for by developer/applicant)

City of Burnet's responsibility:

- I. Furnish and install meter pedestal.
2. Install combination meter socket and breaker box.
3. City of Burnet serviceman will install jumper wires from top of meter socket to pedestal connector and set meter on a routine connects order after all work has been completed.

Underground Specification

**Developer/Applicant
Supplied Material**

**Date: Feb. 22, 2022
Specification Number: 500-100**

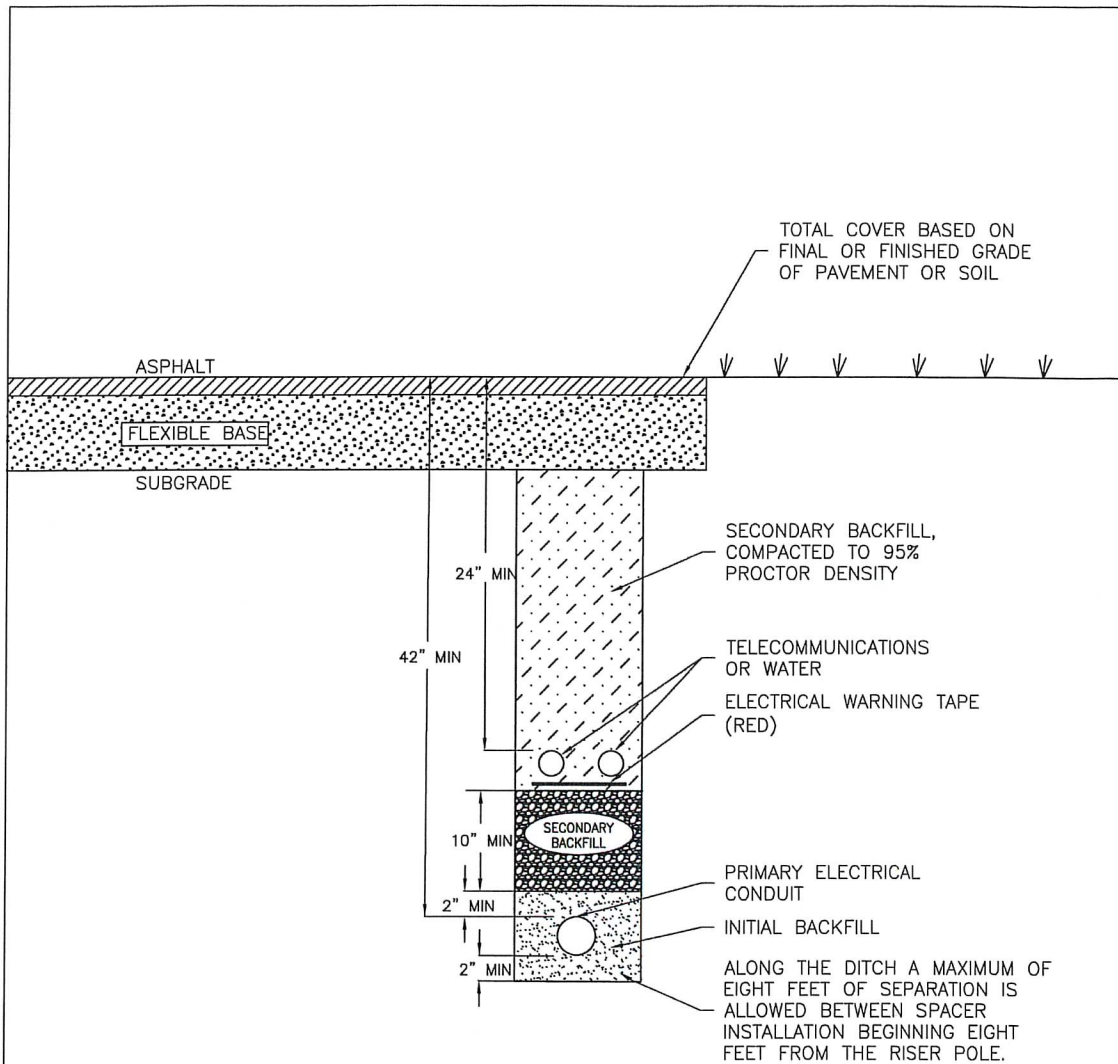

NOTES:

1. USE SCHEDULE 40 ELECTRICAL GRADE PVC CONDUIT ONLY.
2. INITIAL BACKFILL SHALL BE SAND ONLY.
3. SECONDARY BACKFILL SHALL BE SAND OR GRAVEL CONTAINING ROCK, NOT TO EXCEED 3/8" IN DIAMETER.
4. MINIMUM COVER REQUIREMENTS MAY BE REDUCED BY 6" FOR 2" OF 3000 PSI CONCRETE POURED OVER INITIAL BACKFILL, CONTACT CITY OF BURNET FOR INSPECTION BEFORE POURING CONCRETE CAP.
5. IF ANY TYPE OF UNDERGROUND VAULT OR PEDESTAL IS PLANNED, THEN ALL OTHER UTILITIES SHALL BE ROUTED AROUND THESE FACILITIES.
6. ALL CONDUITS SHALL HAVE A MINIMUM OF 2" CLEAR SPACE FROM TRENCH WALLS.
7. FOR TRENCHES UNDER ROADWAYS, ROAD BASE MAY BE UTILIZED IN PLACE OF SELECT MATERIAL AS APPROVED BY 3RD PARTY GEOTECH LABORATORY.
8. TELECOMMUNICATION DEPTH SHALL BE COORDINATED WITH PROVIDER.

SEE SPECIFICATION: 510-010

	CITY OF BURNET DEPARTMENT OF PUBLIC WORKS		SINGLE PHASE CONDUIT ARRANGEMENT FOR PRIMARY ONLY (601 TO 50,000) VOLTS	
	APPROVED BY: STAFF	DATE: 09 / 2021	The Architect/Engineer assumes responsibility for appropriate use of this standard.	DETAIL NUMBER: E-01

Underground Specification

**Developer/Applicant
Supplied Material**

**Date: Feb. 22, 2022
Specification Number: 500-100**

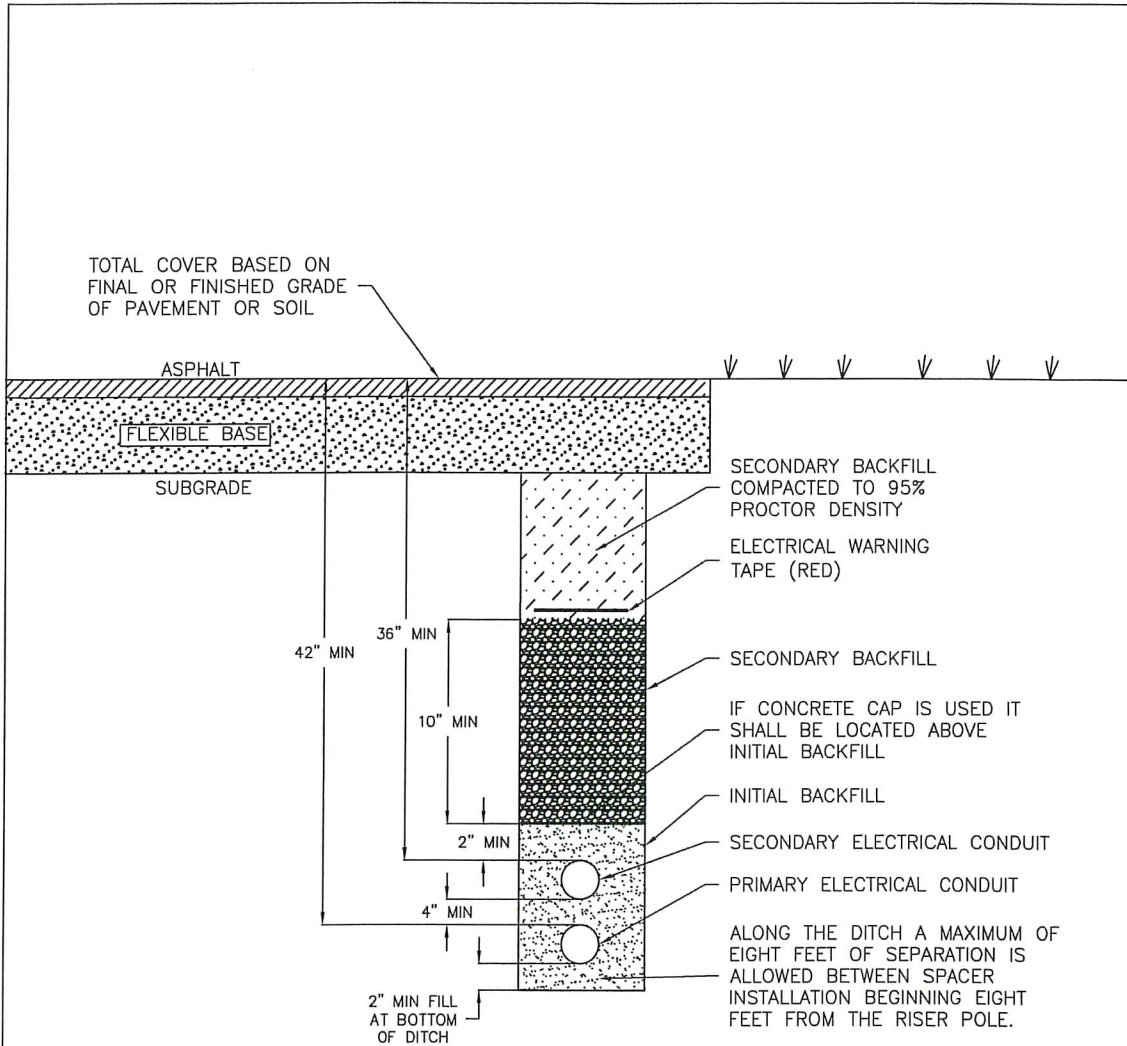

NOTES:

1. USE SCHEDULE 40 ELECTRICAL GRADE PVC CONDUIT ONLY.
2. INITIAL BACKFILL SHALL BE SAND ONLY.
3. SECONDARY BACKFILL SHALL BE SAND OR GRAVEL CONTAINING ROCK, NOT TO EXCEED 3/8" IN DIAMETER.
4. MINIMUM COVER REQUIREMENTS MAY BE REDUCED BY 6" FOR 2" OF 3000 PSI CONCRETE POURED OVER INITIAL BACKFILL, CONTACT CITY OF BURNET FOR INSPECTION BEFORE POURING CONCRETE CAP.
5. IF ANY TYPE OF UNDERGROUND VAULT OR PEDESTAL IS PLANNED, THEN ALL OTHER UTILITIES SHALL BE ROUTED AROUND THESE FACILITIES.
6. ALL CONDUITS SHALL HAVE A MINIMUM OF 2" CLEAR SPACE FROM TRENCH WALLS.
7. FOR TRENCHES UNDER ROADWAYS, ROAD BASE MAY BE UTILIZED IN PLACE OF SELECT MATERIAL AS APPROVED BY 3RD PARTY GEOTECH LABORATORY.
8. TELECOMMUNICATION DEPTH SHALL BE COORDINATED WITH PROVIDER.

SEE SPECIFICATION: 510-012

	CITY OF BURNET DEPARTMENT OF PUBLIC WORKS		SINGLE PHASE CONDUIT ARRANGEMENT PRIMARY AND SECONDARY ONLY	
	APPROVED BY: <div style="text-align: center; font-size: 1.2em;">STAFF</div>	DATE: <div style="text-align: center; font-size: 1.2em;">09 / 2021</div>	The Architect/Engineer assumes responsibility for appropriate use of this standard.	DETAIL NUMBER: <div style="text-align: center; font-size: 1.2em;">E-02</div>

Underground Specification

**Developer/Applicant
Supplied Material**

**Date: Feb. 22, 2022
Specification Number: 500-100**

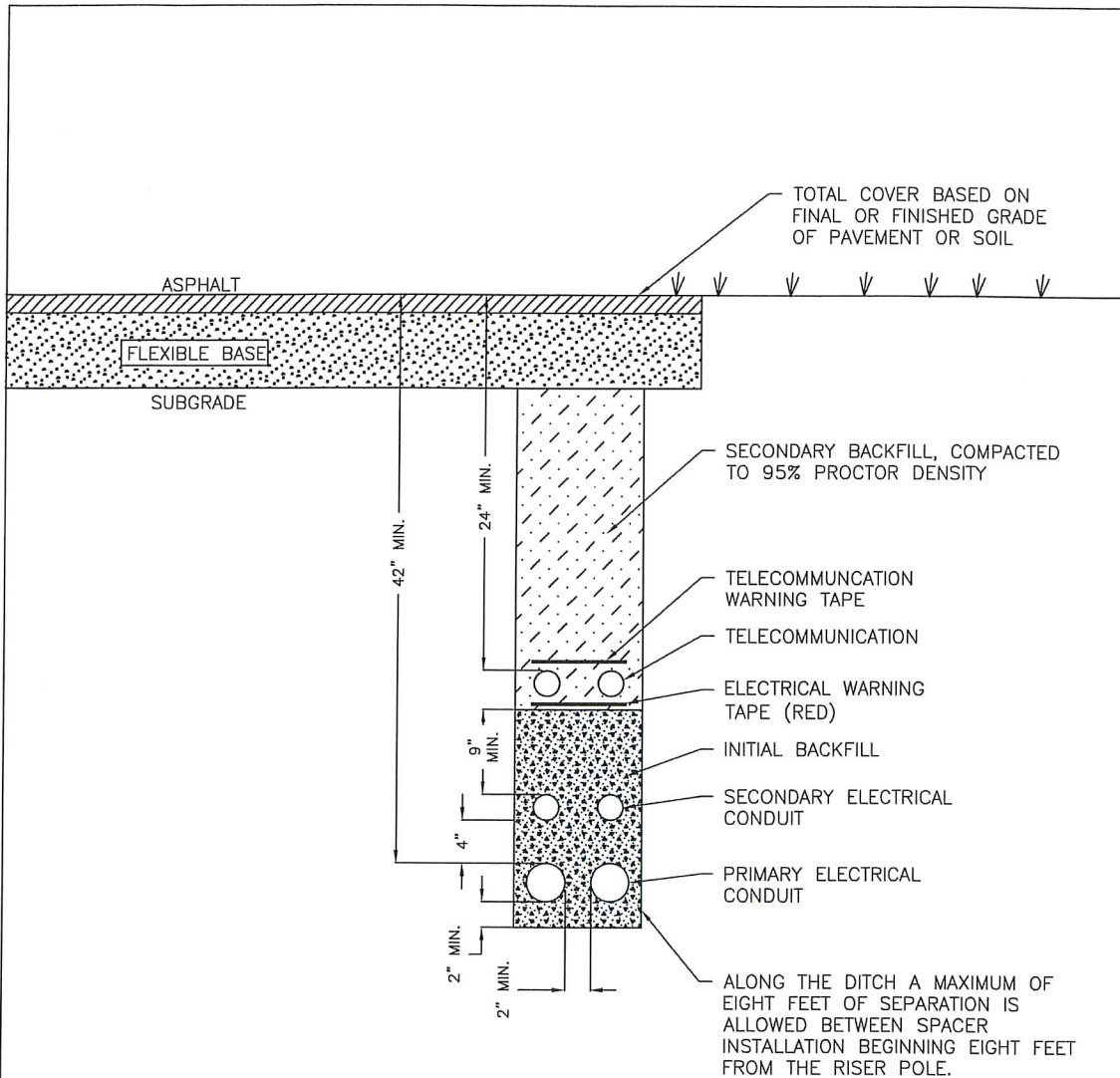

NOTES:

1. USE SCHEDULE 40 ELECTRICAL GRADE PVC CONDUIT ONLY.
2. INITIAL BACKFILL SHALL BE SAND ONLY.
3. SECONDARY BACKFILL SHALL BE SAND OR GRAVEL CONTAINING ROCK, NOT TO EXCEED 3/8" IN DIAMETER.
4. MINIMUM COVER REQUIREMENTS MAY BE REDUCED BY 6" FOR 2" OF 3000 PSI CONCRETE POURED OVER INITIAL BACKFILL, CONTACT CITY OF BURNET FOR INSPECTION BEFORE POURING CONCRETE CAP.
5. IF ANY TYPE OF UNDERGROUND VAULT OR PEDESTAL IS PLANNED, THEN ALL OTHER UTILITIES SHALL BE ROUTED AROUND THESE FACILITIES.
6. ALL CONDUITS SHALL HAVE A MINIMUM OF 2" CLEAR SPACE FROM TRENCH WALLS.
7. FOR TRENCHES UNDER ROADWAYS, ROAD BASE MAY BE UTILIZED IN PLACE OF SELECT MATERIAL AS APPROVED BY 3RD PARTY GEOTECH LABORATORY.
8. TELECOMMUNICATION DEPTH SHALL BE COORDINATED WITH PROVIDER.

SEE SPECIFICATION: 510-014

	CITY OF BURNET DEPARTMENT OF PUBLIC WORKS		TYPICAL CONDUIT ARRANGEMENT JOINT TRENCH WITH TELECOMMUNICATION AND/OR SECONDARY	
	APPROVED BY: <div style="text-align: center; font-weight: bold; font-size: 1.2em;">STAFF</div>	DATE: <div style="text-align: center; font-size: 1.2em;">09 / 2021</div>	The Architect/Engineer assumes responsibility for appropriate use of this standard.	DETAIL NUMBER: <div style="text-align: center; font-size: 1.2em;">E-03</div>

Underground Specification

Developer/Applicant
Supplied Material

Date: Feb. 22, 2022
Specification Number: 500-100

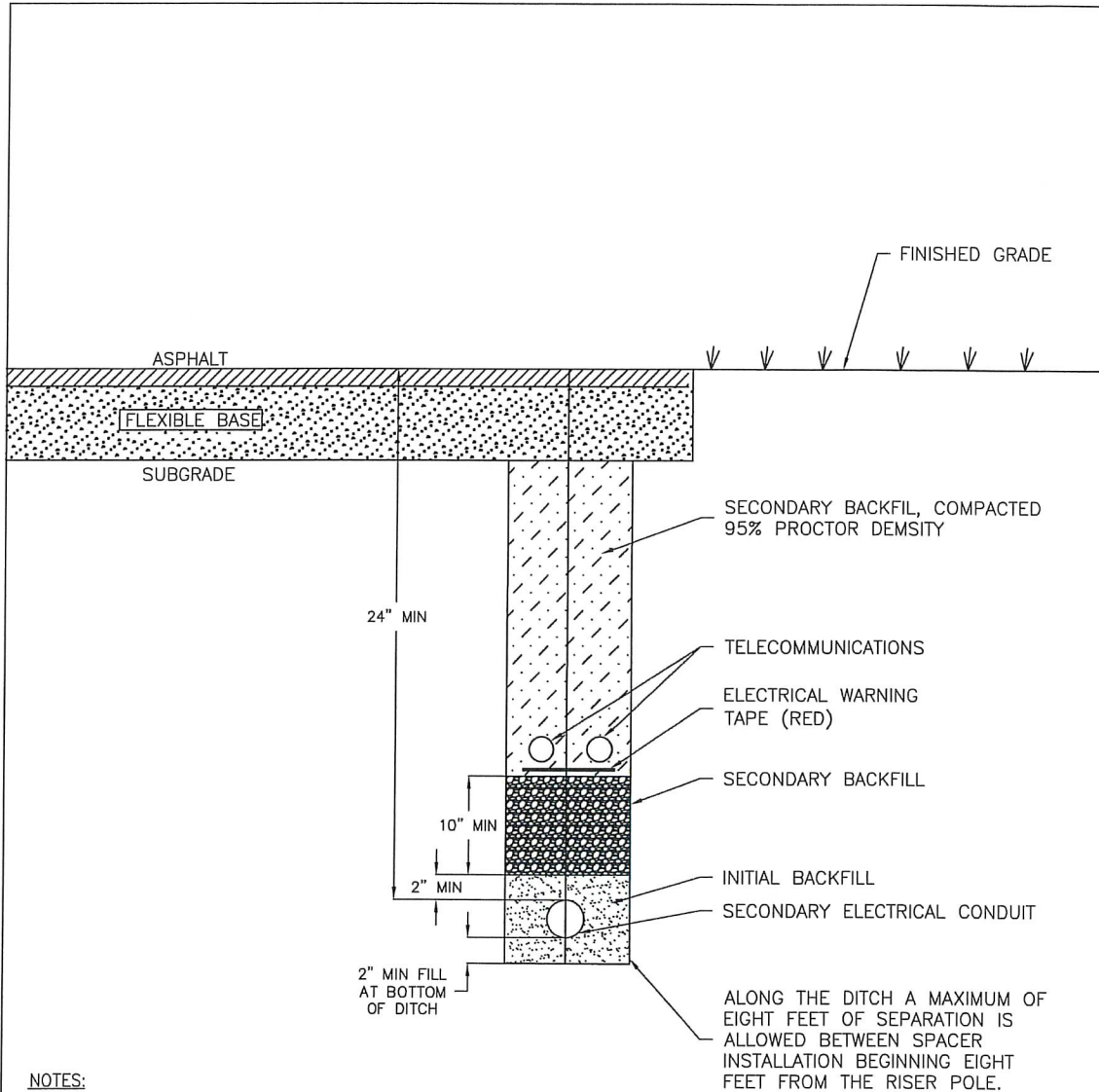

NOTES:

1. USE SCHEDULE 40 ELECTRICAL GRADE PVC CONDUIT ONLY.
2. INITIAL BACKFILL SHALL BE SAND ONLY.
3. SECONDARY BACKFILL SHALL BE SAND OR GRAVEL CONTAINING ROCK, NOT TO EXCEED 3/8" IN DIAMETER.
4. MINIMUM COVER REQUIREMENTS MAY BE REDUCED BY 6" FOR 2" OF 3000 PSI CONCRETE POURED OVER INITIAL BACKFILL, CONTACT CITY OF BURNET FOR INSPECTION BEFORE POURING CONCRETE CAP.
5. IF ANY TYPE OF UNDERGROUND VAULT OR PEDESTAL IS PLANNED, THEN ALL OTHER UTILITIES SHALL BE ROUTED AROUND THESE FACILITIES.
6. ALL CONDUITS SHALL HAVE A MINIMUM OF 2" CLEAR SPACE FROM TRENCH WALLS.
7. FOR TRENCHES UNDER ROADWAYS, ROAD BASE MAY BE UTILIZED IN PLACE OF SELECT MATERIAL AS APPROVED BY 3RD PARTY GEOTECH LABORATORY.
8. TELECOMMUNICATION DEPTH SHALL BE COORDINATED WITH PROVIDER.

SEE SPECIFICATION: 510-016

	CITY OF BURNET DEPARTMENT OF PUBLIC WORKS		SINGLE PHASE CONDUIT ARRANGEMENT FOR SECONDARY (0 TO 600 VOLTS)	
	APPROVED BY: <div style="text-align: center; font-size: 1.2em;">STAFF</div>	DATE: <div style="text-align: center; font-size: 1.2em;">09 / 2021</div>	The Architect/Engineer assumes responsibility for appropriate use of this standard.	DETAIL NUMBER: <div style="text-align: center; font-size: 1.2em;">E-04</div>

Underground Specification

Developer/Applicant
Supplied Material

Date: Feb. 22, 2022
Specification Number: 500-100

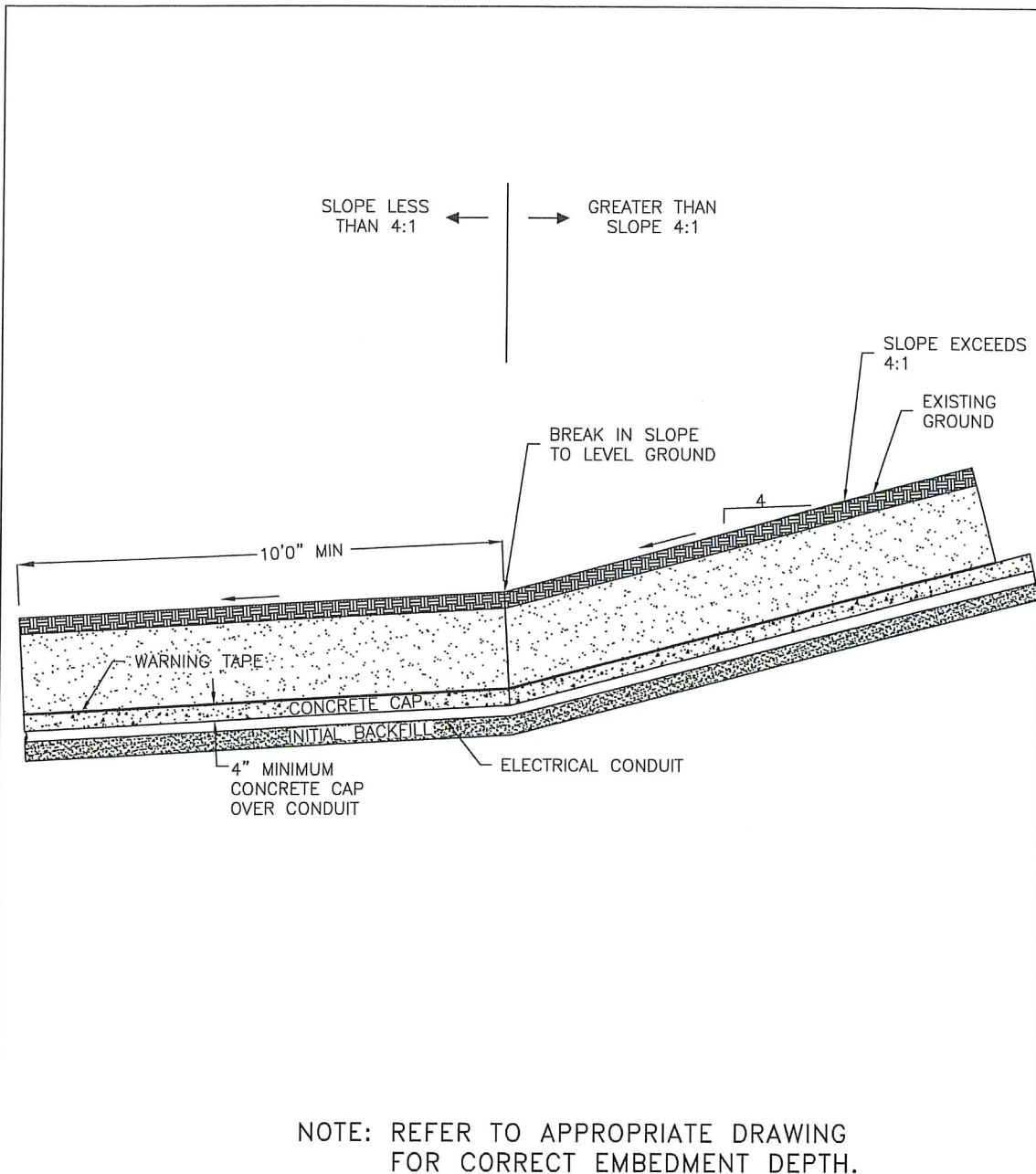

SEE SPECIFICATION: 510-027

	CITY OF BURNET DEPARTMENT OF PUBLIC WORKS		CONDUIT INSTALLATION ON SLOPES GREATER THAN 4:1 WITH CONCRETE CAP	
	APPROVED BY: STAFF	DATE: 09 / 2021	The Architect/Engineer assumes responsibility for appropriate use of this standard.	DETAIL NUMBER: E-05

Underground Specification

Developer/Applicant
Supplied Material

Date: Feb. 22, 2022
Specification Number: 500-100

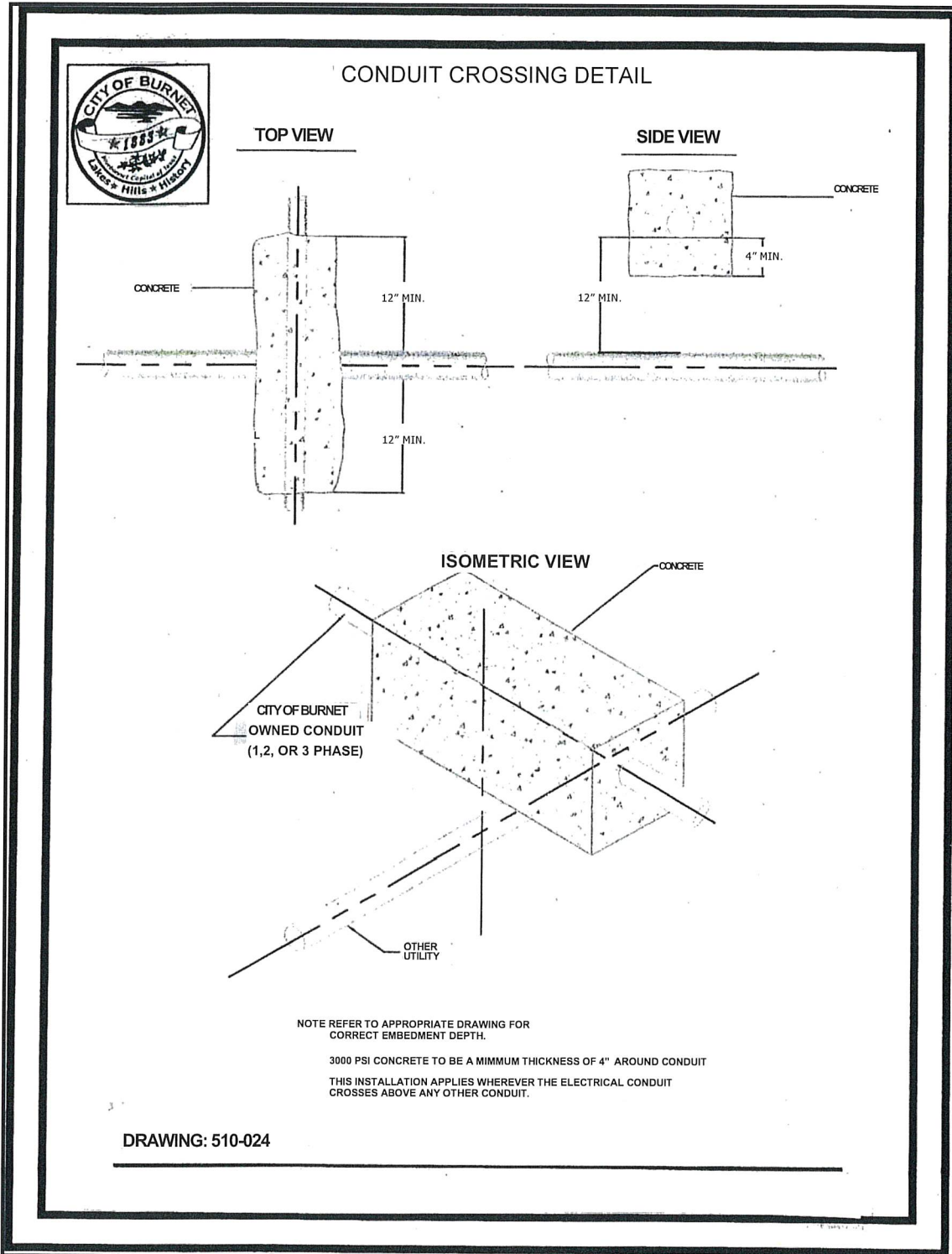

Underground Specification

**Developer/Applicant
Supplied Material**

**Date: Feb. 22, 2022
Specification Number: 500-100**

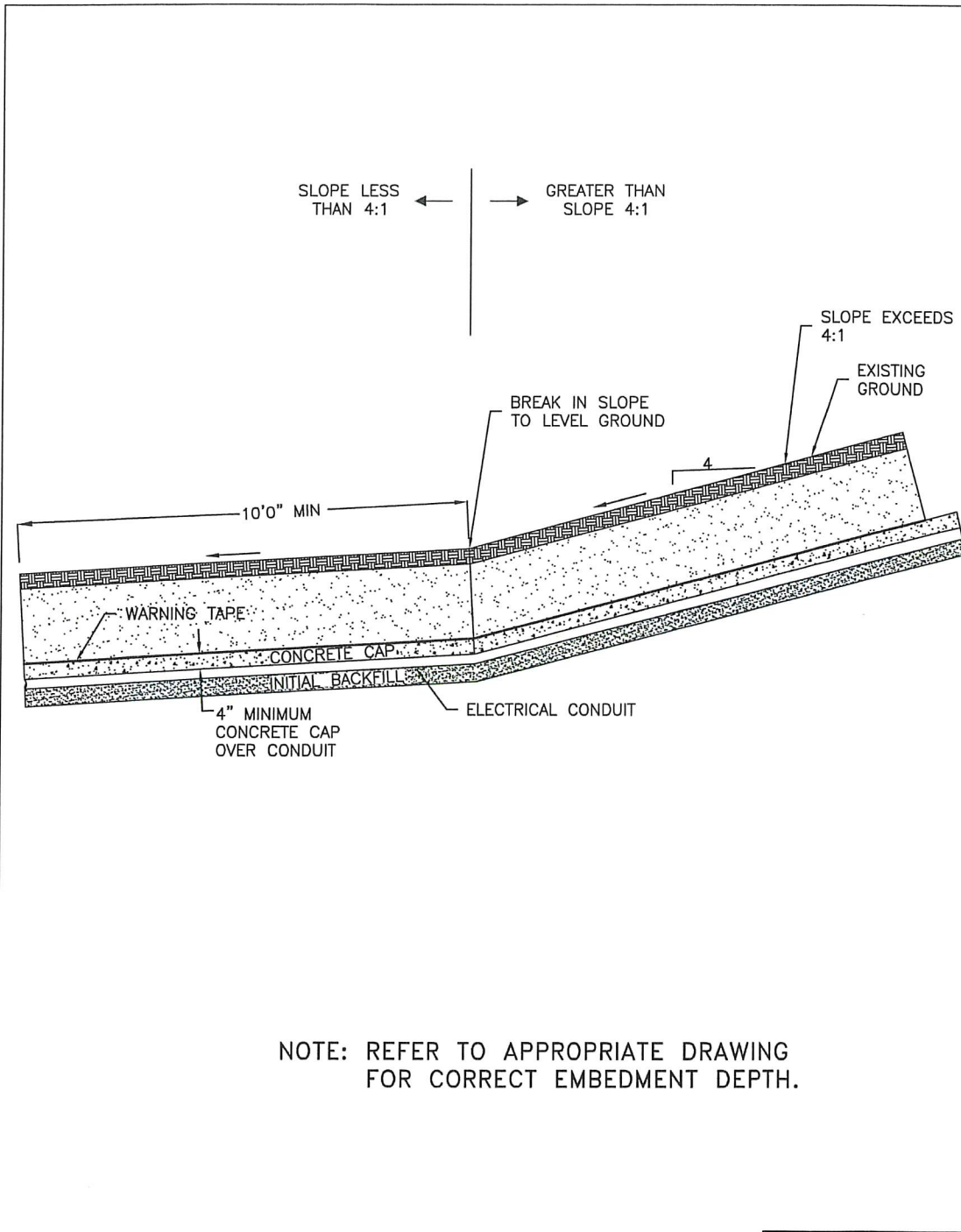

NOTE: REFER TO APPROPRIATE DRAWING
FOR CORRECT EMBEDMENT DEPTH.

SEE SPECIFICATION: 510-027

	CITY OF BURNET DEPARTMENT OF PUBLIC WORKS		CONDUIT INSTALLATION ON SLOPES GREATER THAN 4:1 WITH CONCRETE CAP	
	APPROVED BY: STAFF	DATE: 09 / 2021	The Architect/Engineer assumes responsibility for appropriate use of this standard.	DETAIL NUMBER: E-07

Underground Specification

Developer/Applicant
Supplied Material

Date: Feb. 22, 2022
Specification Number: 500-100

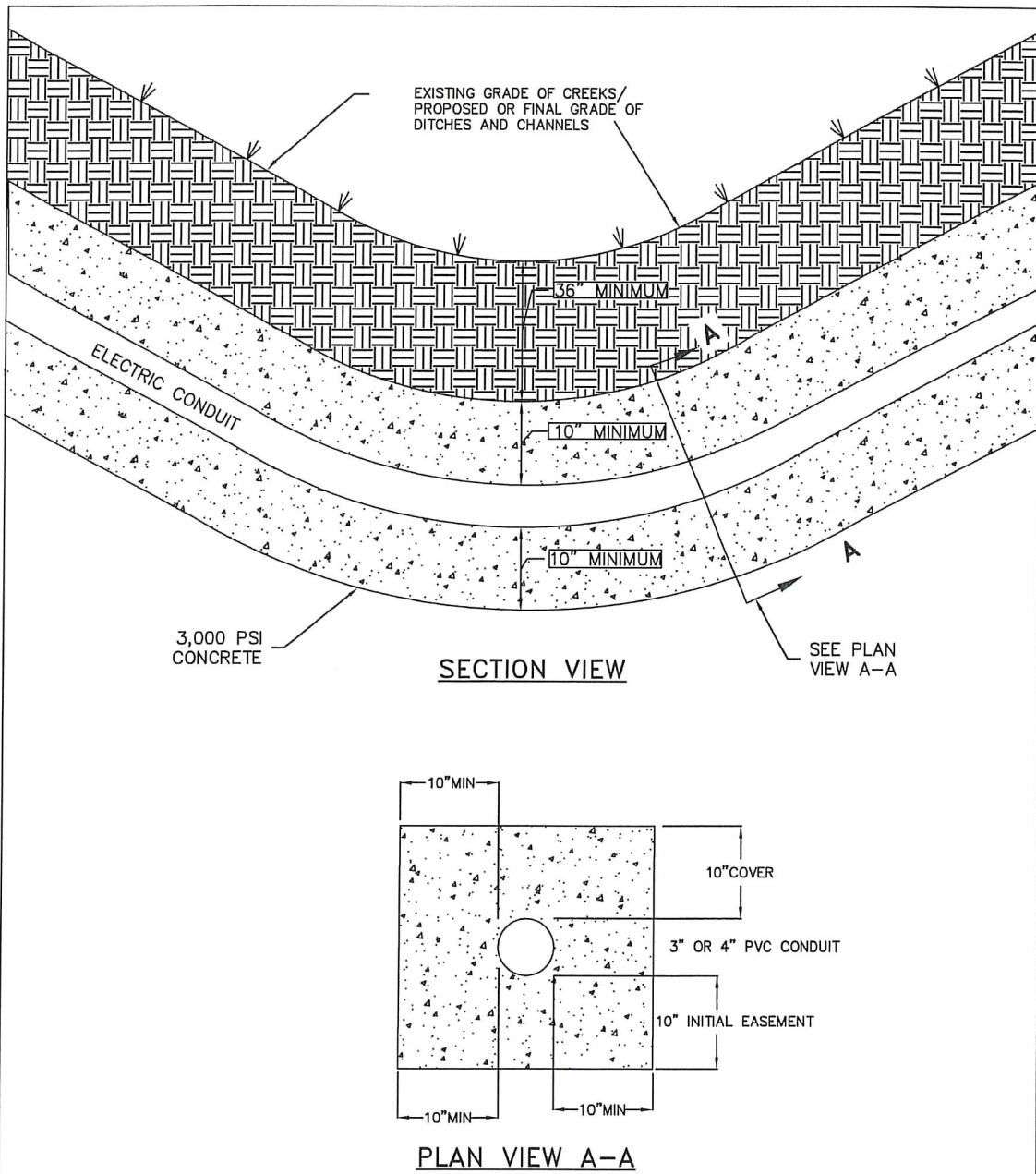

NOTE: REFER TO APPROPRIATE DRAWING FOR
CORRECT EMBEDMENT DEPTH.

SEE SPECIFICATION: 510-028



CITY OF BURNET
DEPARTMENT OF PUBLIC WORKS

APPROVED BY: **STAFF** DATE: **09 / 2021**

**CONDUIT INSTALLATION
IN FLOOD PRONE AREAS**

The Architect/Engineer assumes responsibility for appropriate use of this standard. **DETAIL NUMBER: E-08**

Underground Specification

Developer/Applicant
Supplied Material

Date: Feb. 22, 2022
Specification Number: 500-100

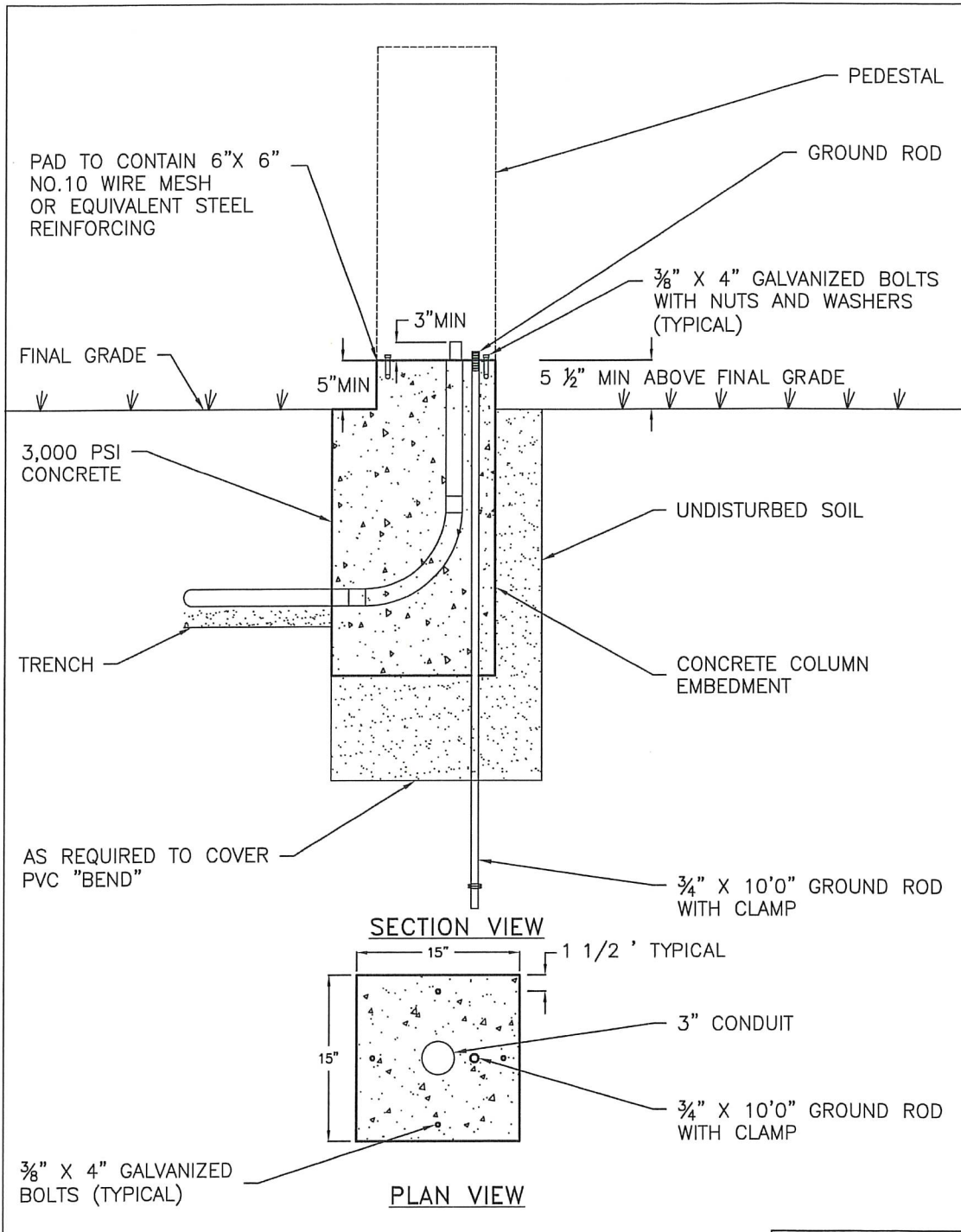

SEE SPECIFICATION: 520-010

	CITY OF BURNET DEPARTMENT OF PUBLIC WORKS	TYPICAL PAD FOR SINGLE OR MULTIPLE SERVICE METER PEDESTAL	
	APPROVED BY: STAFF	DATE: 09 / 2021	The Architect/Engineer assumes responsibility for appropriate use of this standard.

Underground Specification

Developer/Applicant
Supplied Material

Date: Feb. 22, 2022
Specification Number: 500-100

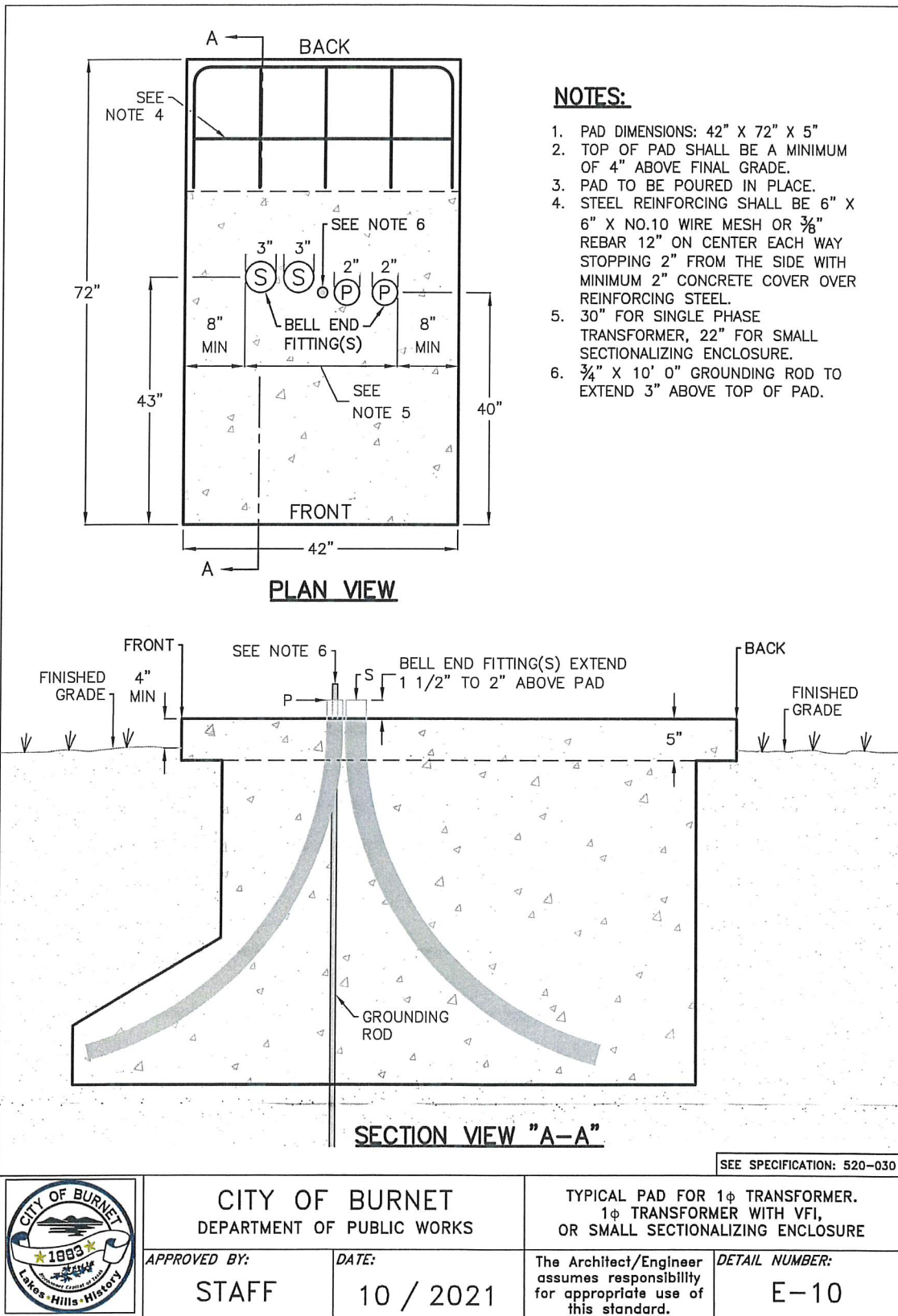

NOTES:

1. PAD DIMENSIONS: 42" X 72" X 5"
2. TOP OF PAD SHALL BE A MINIMUM OF 4" ABOVE FINAL GRADE.
3. PAD TO BE POURED IN PLACE.
4. STEEL REINFORCING SHALL BE 6" X 6" X NO.10 WIRE MESH OR 3/8" REBAR 12" ON CENTER EACH WAY STOPPING 2" FROM THE SIDE WITH MINIMUM 2" CONCRETE COVER OVER REINFORCING STEEL.
5. 30" FOR SINGLE PHASE TRANSFORMER, 22" FOR SMALL SECTIONALIZING ENCLOSURE.
6. 3/4" X 10' 0" GROUNDING ROD TO EXTEND 3" ABOVE TOP OF PAD.

POURED IN PLACE VAULTS

Poured in place vault Specifications:

- 1.) Concrete to be a minimum of 3,000 P.S.I. design strength.
- 2.) All walls to be a minimum of 9" thick.
- 3.) Steel reinforcing shall be 6" by 6" number 10 wire mesh or $\frac{3}{8}$ " rebar minimum.
- 4.) $\frac{3}{8}$ " Steel rebar shall be spaced A maximum 12" apart vertically.
- 5.) Footing to extend to undisturbed soil or rock.
- 6.) See individual vault drawings for actual dimensions.

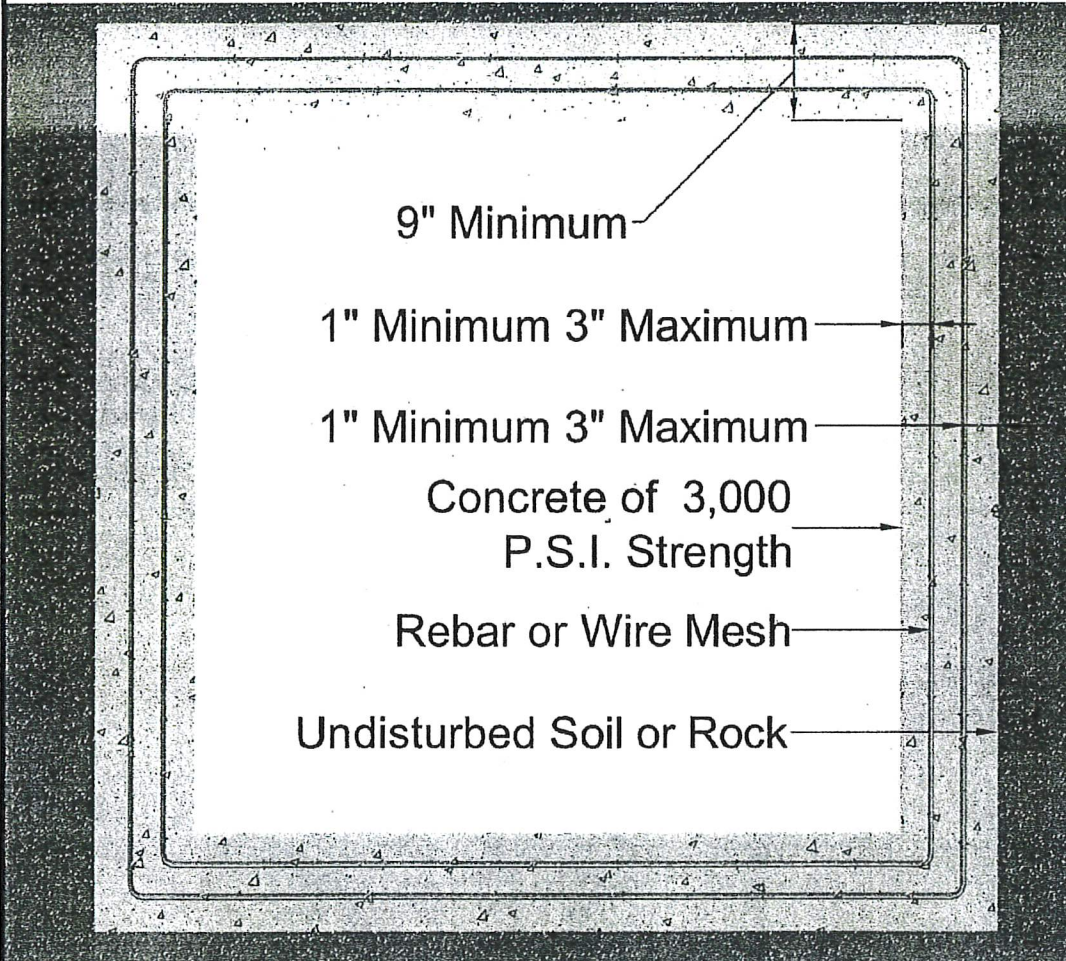

DRAWING: 530-000

Underground Specification

Developer/Applicant
Supplied Material

Date: Feb. 22, 2022
Specification Number: 500-100



SMALL PAD FOR
3Ø SECTIONALIZING ENCLOSURE
(56" x 46")

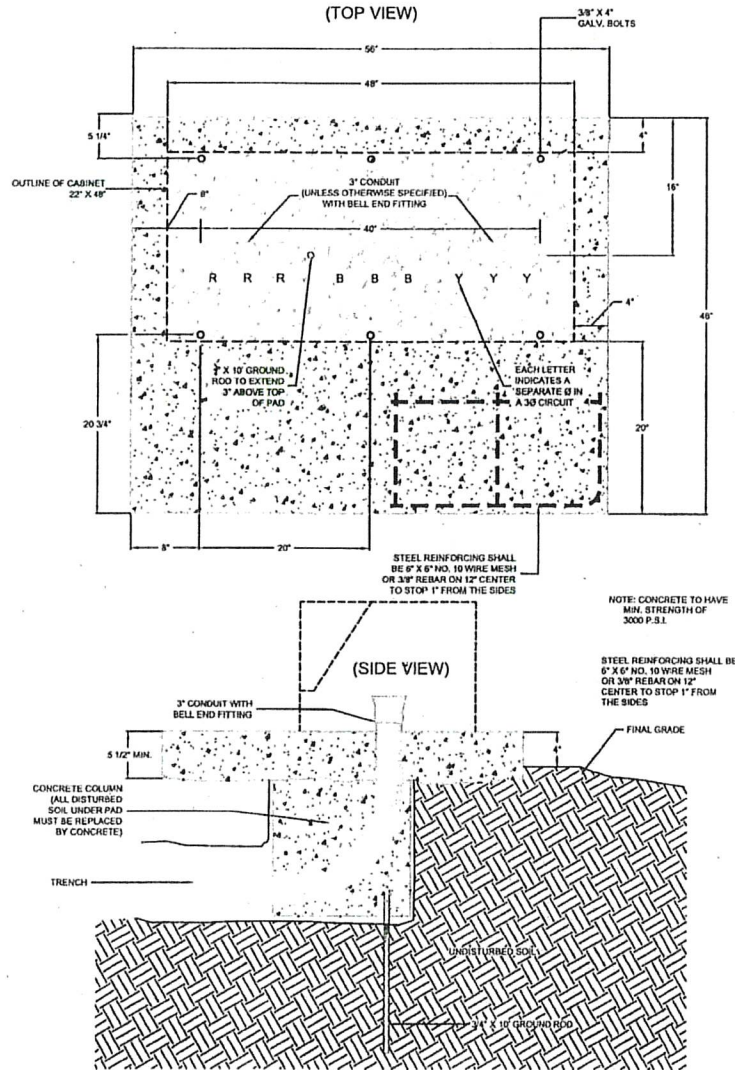

DRAWING: 530-020

Underground Specification

Developer/Applicant
Supplied Material

Date: Feb. 22, 2022
Specification Number: 500-100

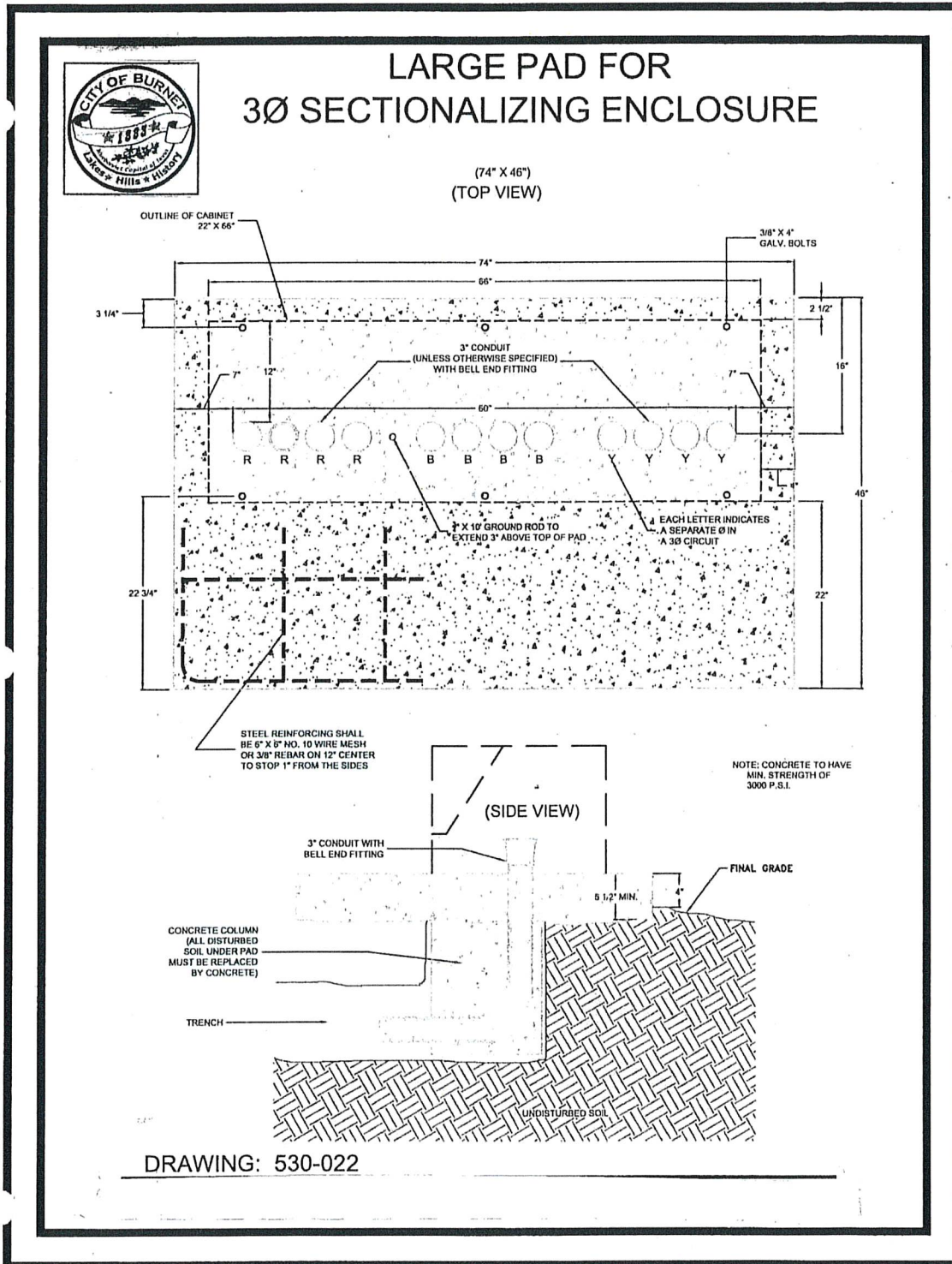

Underground Specification

Developer/Applicant
Supplied Material

Date: Feb. 22, 2022
Specification Number: 500-100



3Ø TRANSFORMER PAD 45-500 kVA

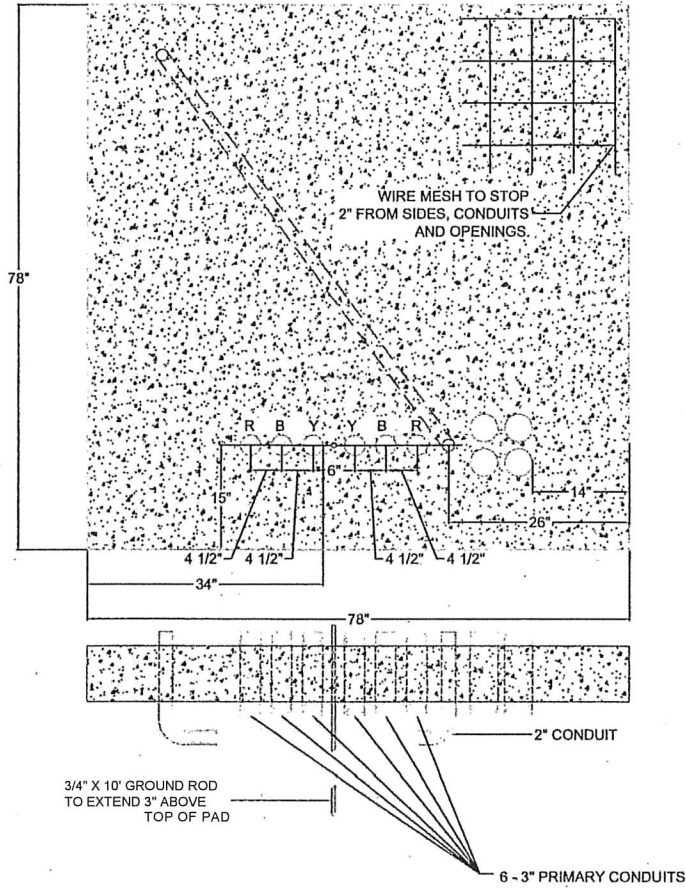

1. CONCRETE TESTING, 4000 POUNDS PER SQUARE INCH; 4%-6% ENTRAINED AIR, 3/4" MAXIMUM SIZE AGGREGATE.
2. REINFORCING STEEL, ASTM-A615 GRADE 60, PLACE APPROX. 6" O.C. EACH WAY AND SECURELY TOGETHER (#4 MIN).
3. MINIMUM CONCRETE COVER OVER REINFORCING STEEL 2 INCHES UNLESS NOTED.
4. WOOD FLOAT FINISH, LEAVING NO DEPRESSIONS.

DRAWING: 530-030

Underground Specification

Developer/Applicant
Supplied Material

Date: Feb. 22, 2022
Specification Number: 500-100

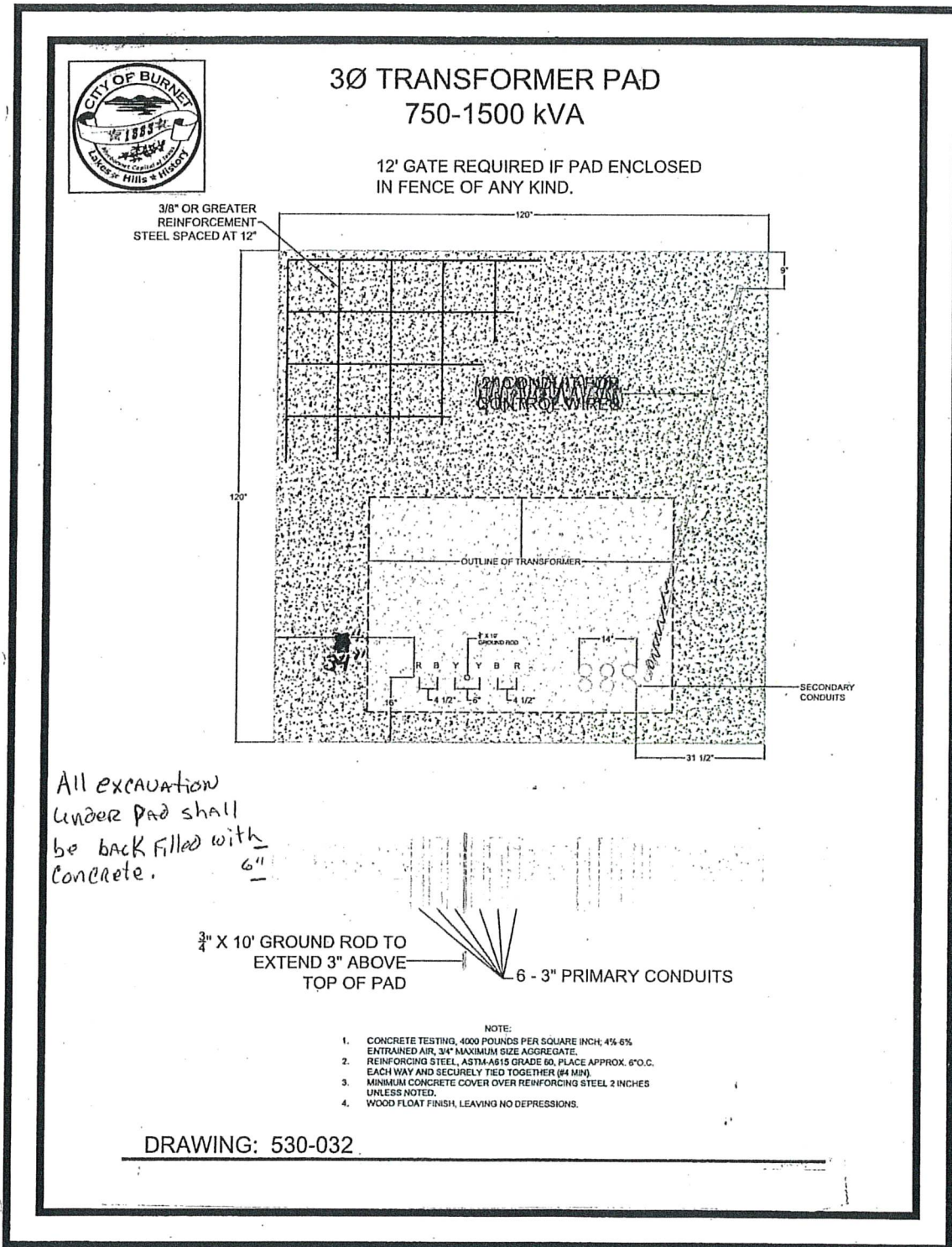

Underground Specification

Developer/Applicant
Supplied Material

Date: Feb. 22, 2022
Specification Number: 500-100

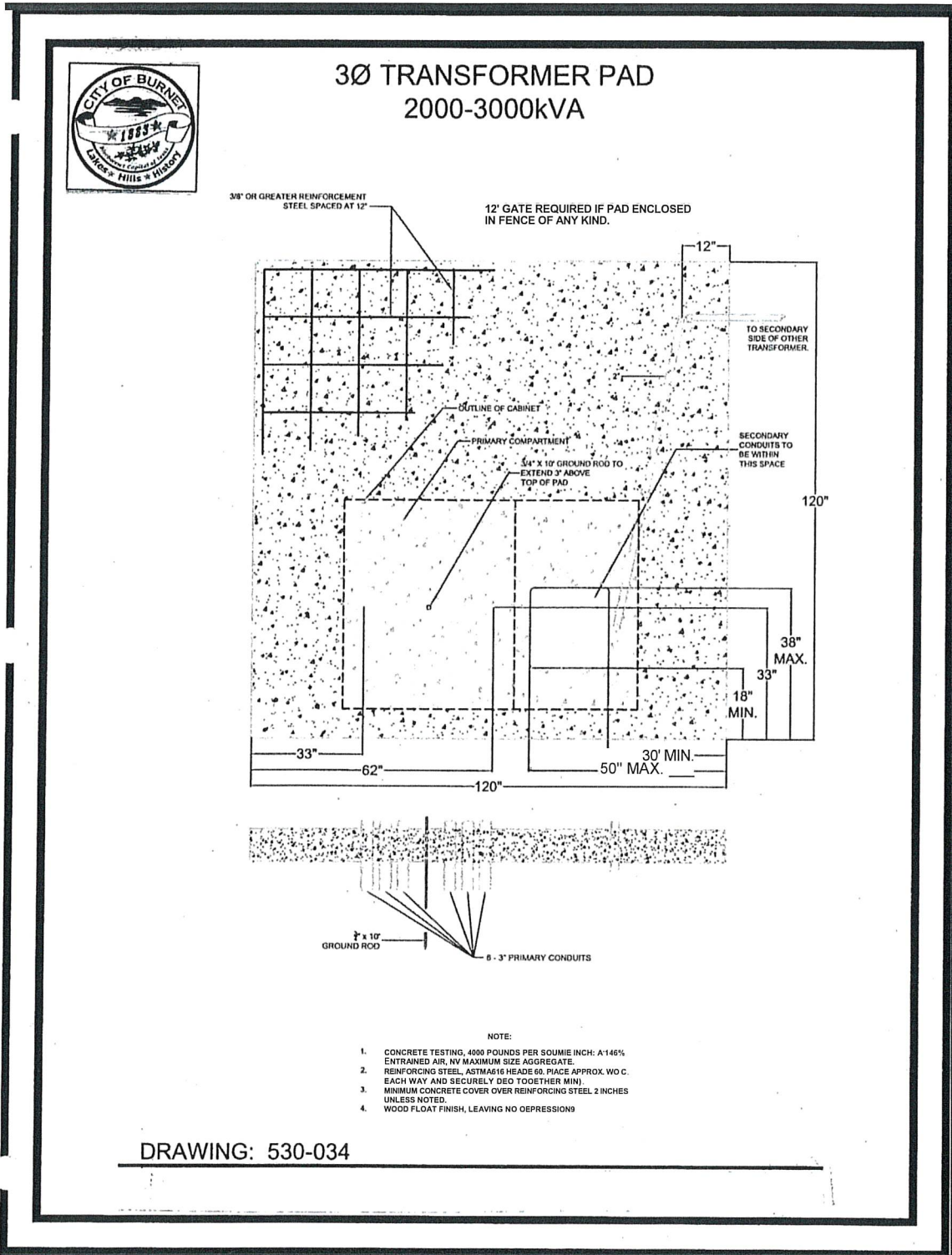

Underground Specification

Developer/Applicant
Supplied Material

Date: Feb. 22, 2022
Specification Number: 500-100

The 144" side wall shall have two pulling eyes located 48" apart, evenly spaced between inside walls, and 18" from the bottom of the vault. The 72" side wall shall have one pulling eye located in the center of the wall and 18" from the bottom of the vault. All pulling eyes to be rated for a minimum of 5,000 pounds each. 6" above the bottom of the vault, an 8" knockout shall extend around the entire perimeter of the vault (except for 6" from each corner) for conduits to be brought in. Knockouts should be 1" thick and flush with the inside of the vault. The vault shall be 7' deep. The vault shall be installed on a minimum 6" deep bed of 1" diameter gravel.

Each vault shall be supplied with either a 10.0' ground rod driven in the vault floor or a minimum 100 feet of #6 bare copper wire buried no less than 18" deep in the earth and meeting the National Electric Safety Code Rule #09483.

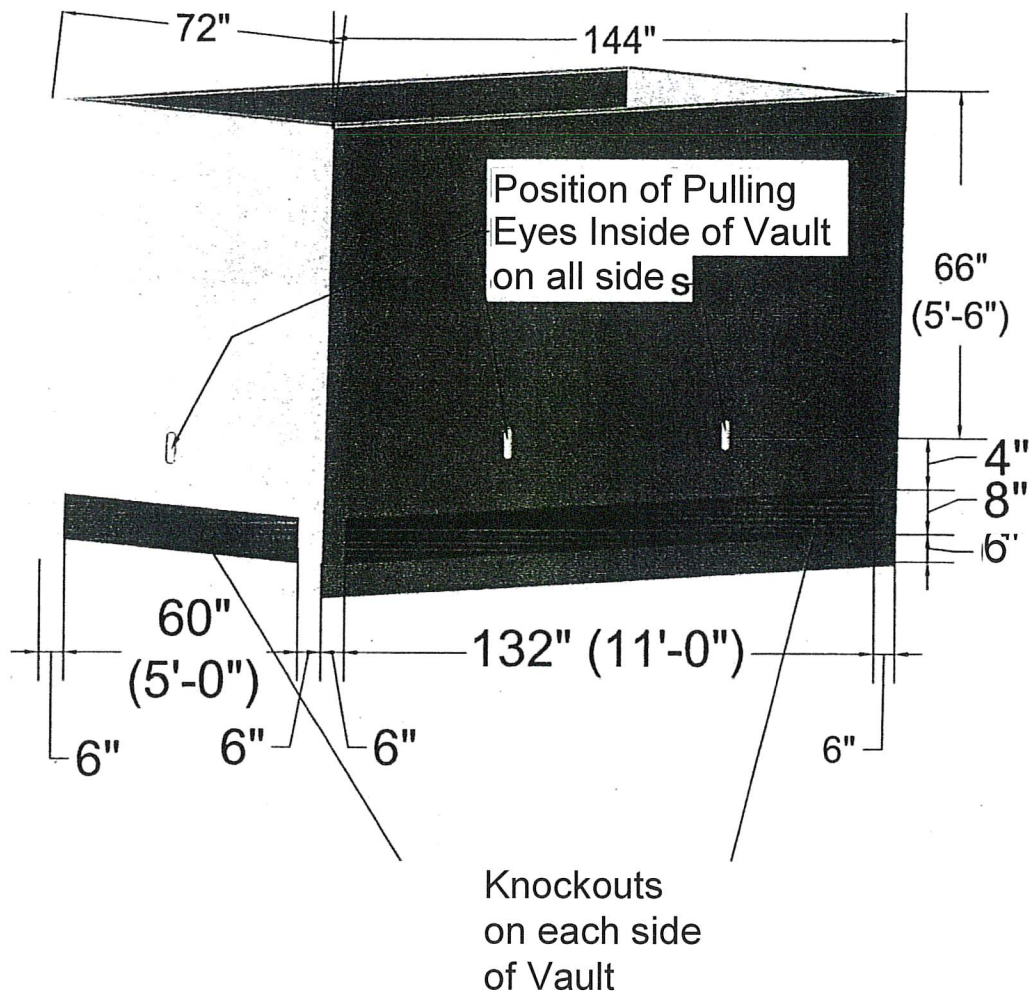

DRAWING: 530-050

Lid for Submersible Switchgear and Splice Box

(For use on vault 530-050)

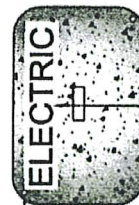
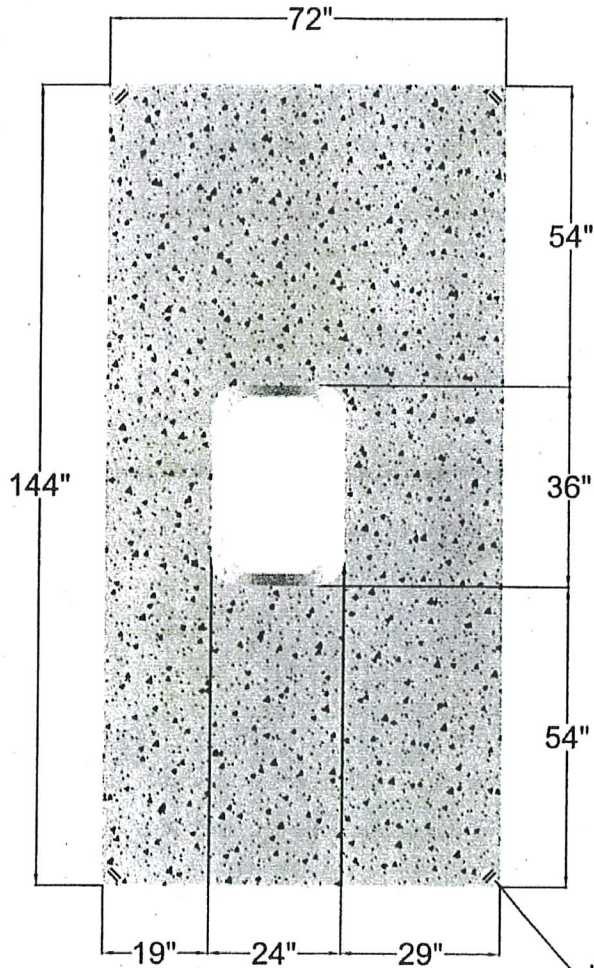

Access Lid shall be identified "ELECTRIC"

Access Lid to be Traffic Rated and secured by "Penta-head" bolts.

Lifting Eyes to accommodate a chain shall be located at each corner. They shall be flush with the top of the lid.

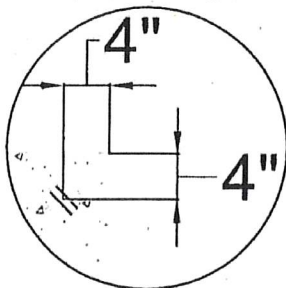

Lifting Eye Location

DRAWING: 530-051

Vault for Combination Lid and 750 kVA and larger Transformers

The 96" side wall shall have two pulling eyes located 30" apart, evenly spaced between inside walls, and 18" from the bottom of the vault. The 72" side wall shall have one pulling eye located in the center of the wall and 18" from the bottom of the vault. All pulling eyes to be rated for a minimum of 5,000 pounds each. 6" above the bottom of the vault, an 8" knockout shall extend around the entire perimeter of the vault (except for 6" from each corner) for conduits to be brought in. Knockouts should be 1" thick and flush with the inside of the vault. The vault shall be 4' deep. The vault shall be installed on a minimum 6" deep bed of $\frac{1}{2}$ " to $\frac{3}{4}$ " diameter gravel.

Each vault shall be supplied with either a ten foot ground rod driven in the vault or a minimum 100 feet of #6 copper wire buried no less than eighteen inches deep in the earth and meeting the National Electric Safety Code Rule #094B3

Position of Pulling
Eyes inside of
Vault on all sides.

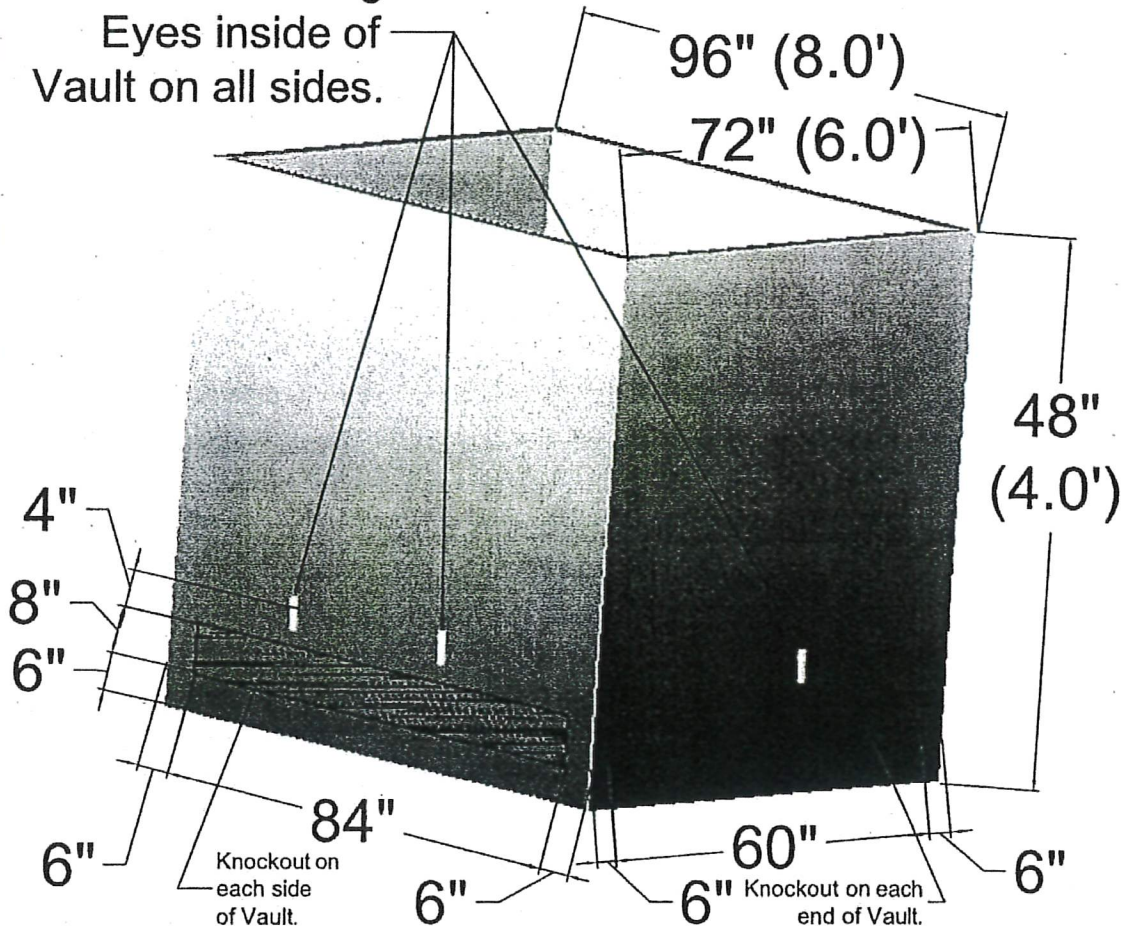

DRAWING: 530-060

Combination Lid (For use on Vault 530-060)

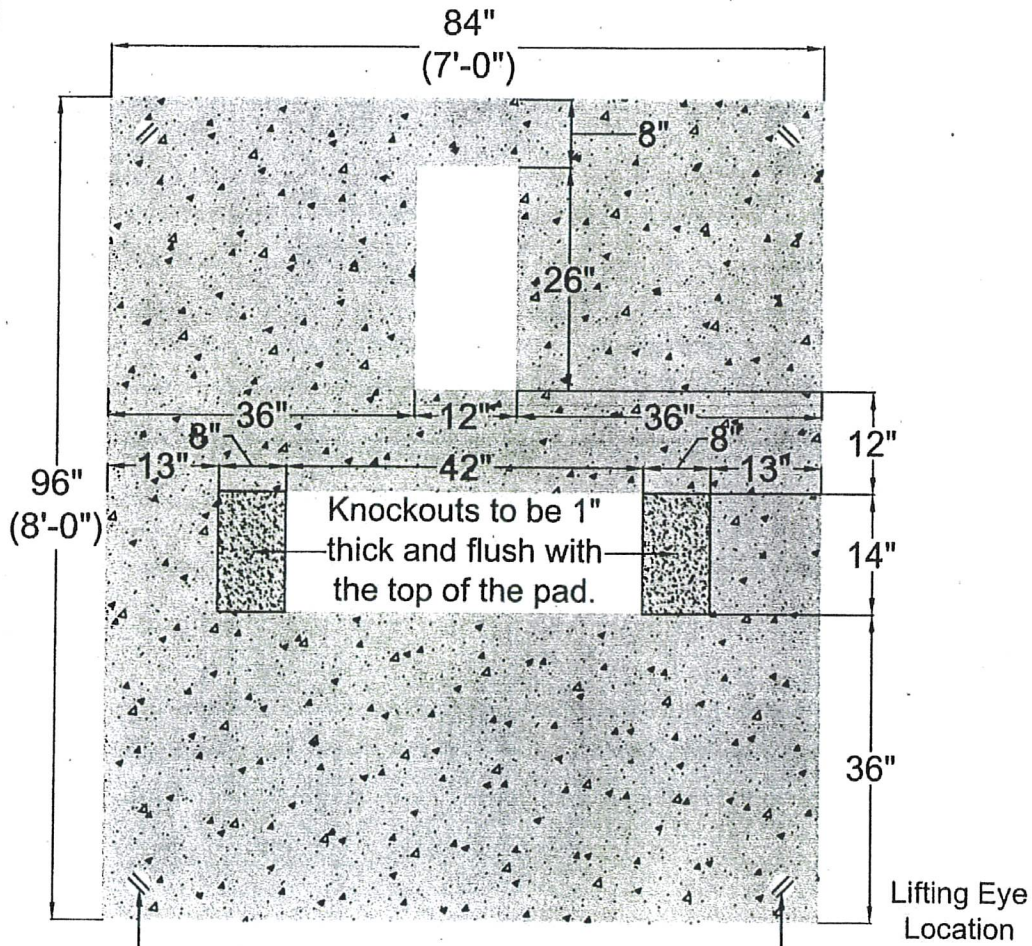

Lifting Eyes to accommodate a chain shall be located at each corner. They shall be flush with the top of the lid.

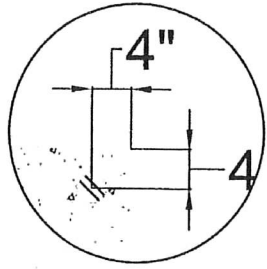

DRAWING: 530-061

Lid for 750-3000 kVA 3-Phase Transformer

(For use on Vault 530-060)

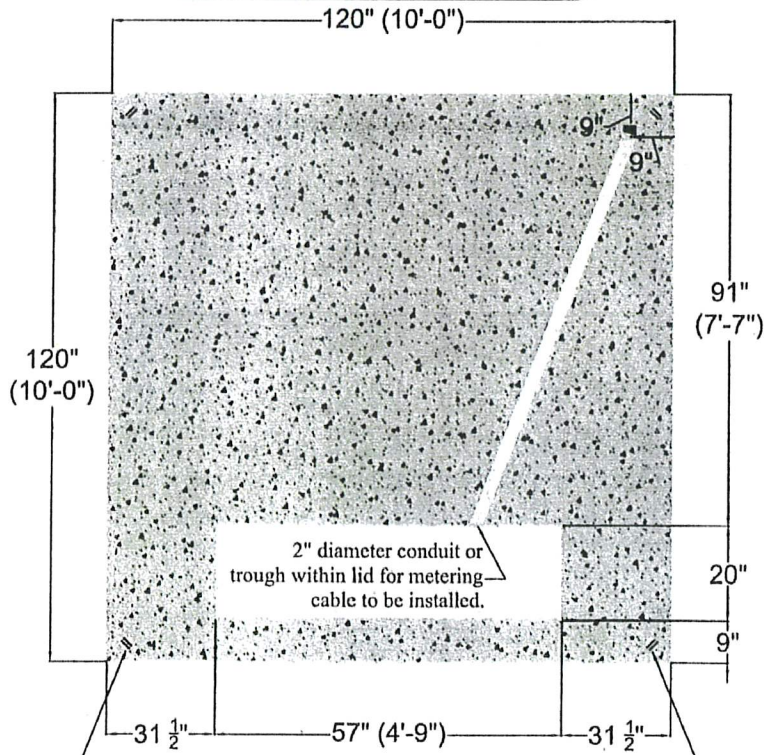
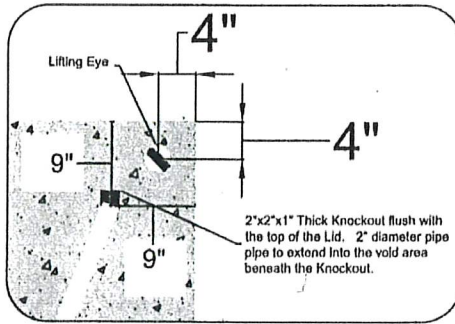

Lifting Eyes to accommodate a chain shall be located at each corner. They shall be flush with the top of the lid.

DRAWING: 530-065

Underground Specification

Developer/Applicant
Supplied Material

Date: Feb. 22, 2022
Specification Number: 500-100

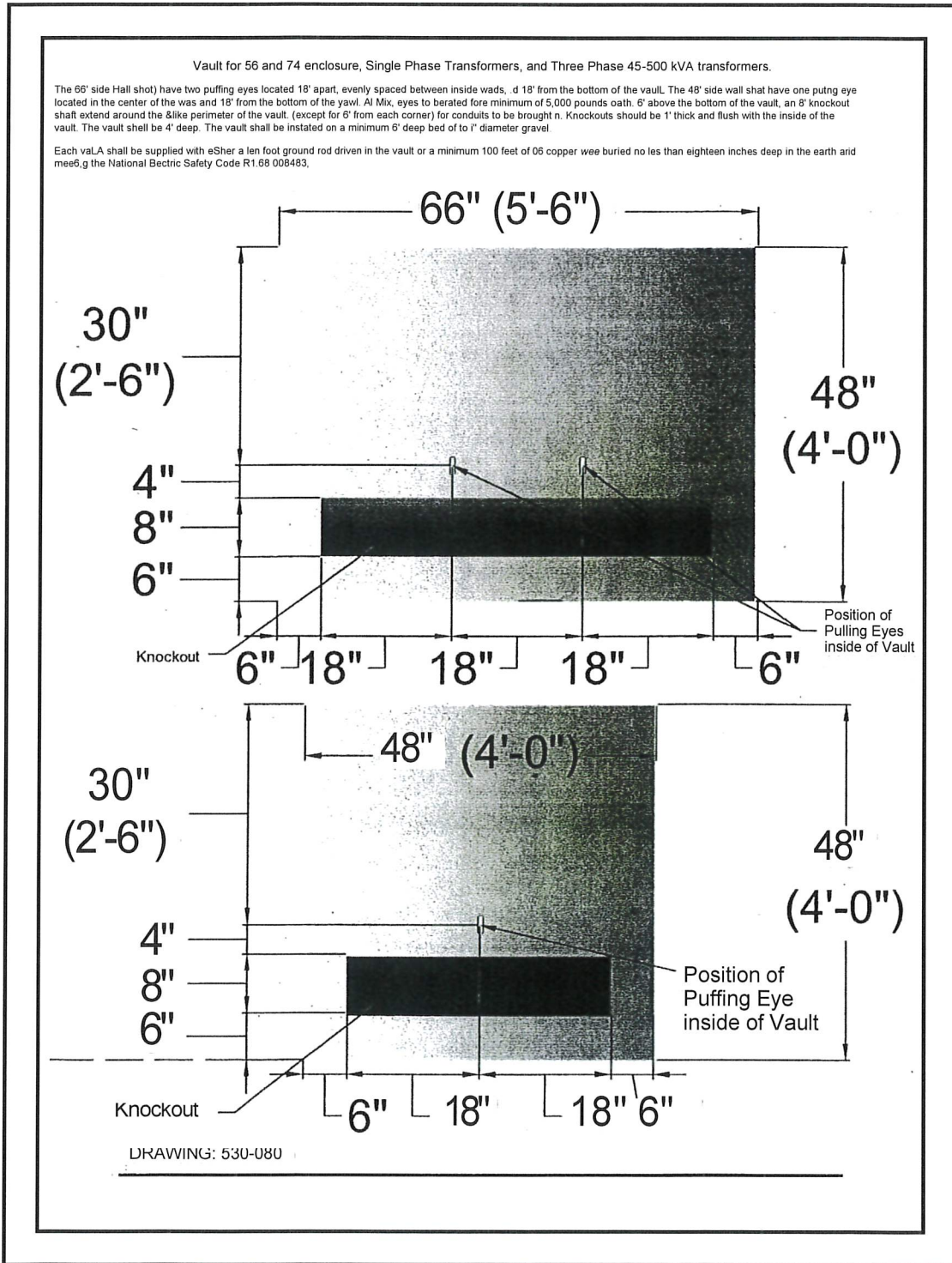

Lid for 56 and 74 Enclosures

(For use on vault 530-080)

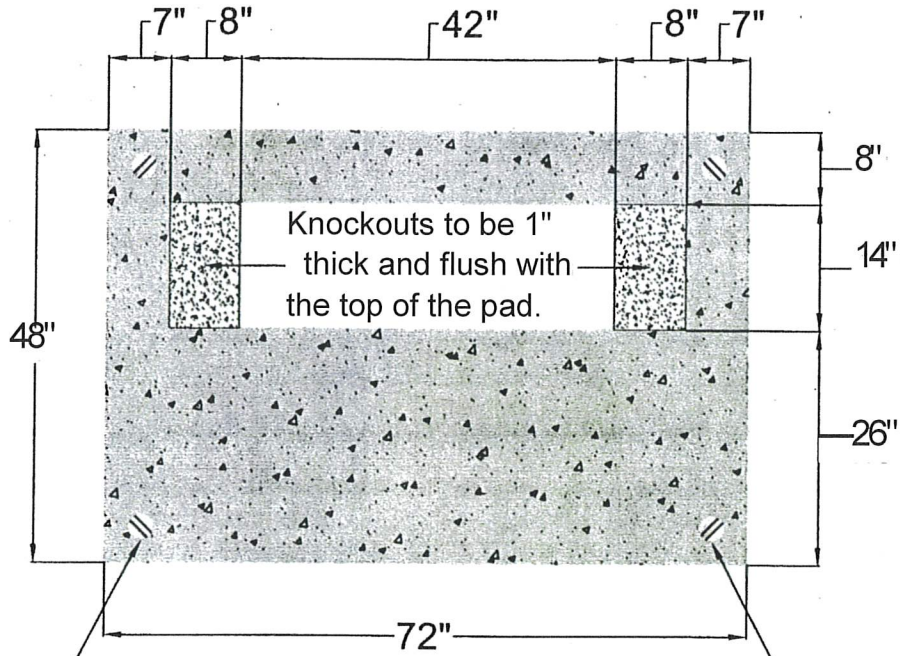

Lifting Eyes to accommodate a chain shall be located at each corner. They shall be flush with the top of the lid.

Lifting Eye Location

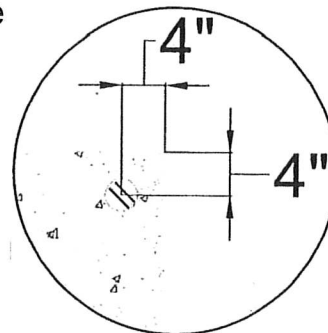

DRAWING: 530-081

Single Phase Transformer Lid

(For use on vault 530-080)

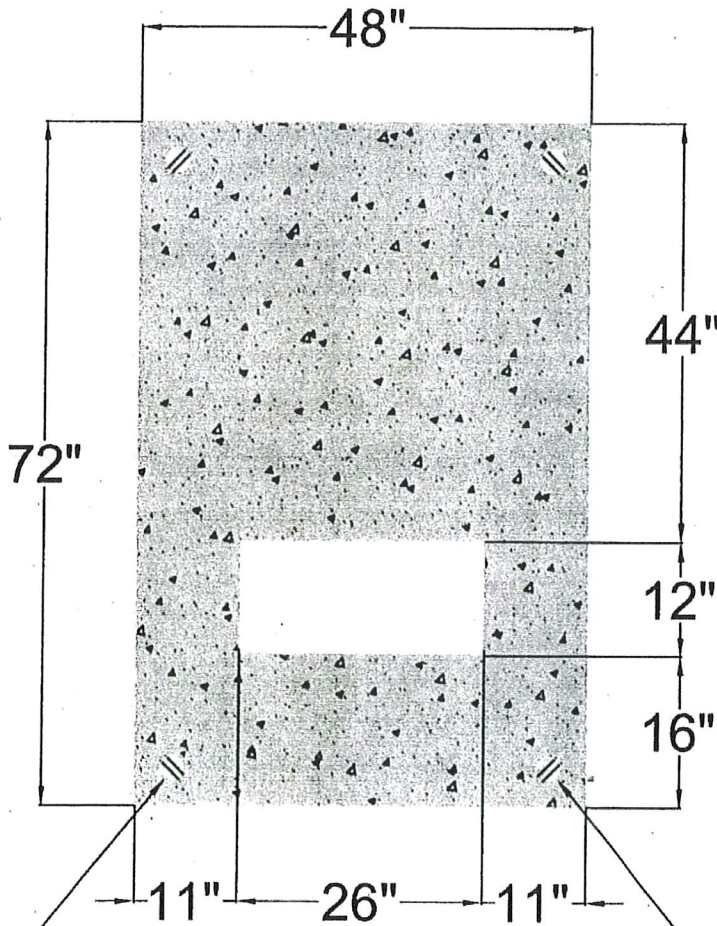

Lifting Eyes to accommodate a chain shall be located at each corner. They shall be flush with the top of the lid.

Lifting Eye Location

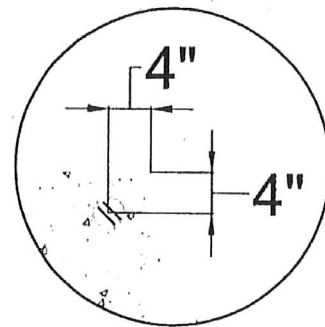

DRAWING: 530-085

45-500 kVA 3-Phase Transformer Lid

(For use on vault 530-080)

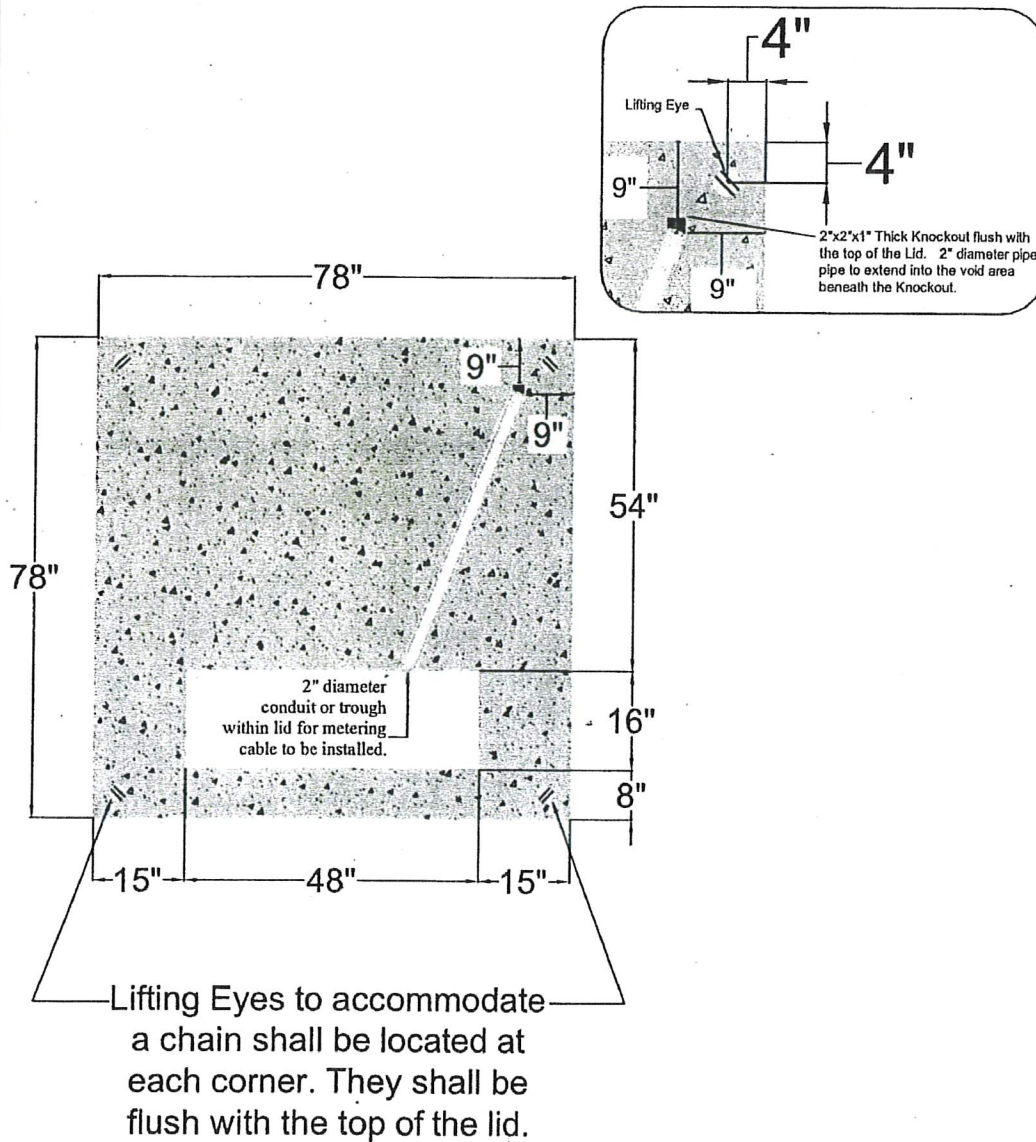

DRAWING: 530-086

Underground Specification

Developer/Applicant
Supplied Material

Date: Feb. 22, 2022
Specification Number: 500-100

Vault for Switchgears

Each side wall shall have two pulling eyes located 24" apart, evenly spaced between inside walls, and 18" from the bottom of the vault. All pulling eyes to be rated for a minimum of 5,000 pounds each. 6" above the bottom of the vault, an 8" Knockout shall extend around the entire perimeter of the vault (except for 6" from each corner) for conduits to be brought in. Knockouts should be 1" thick and flush with the inside of the vault. The vault shall be 4' deep. The vault shall be installed on a minimum 6" deep bed of 1/2" to 1" diameter gravel.

Each vault shall be supplied with either a ten foot ground rod driven in the vault or a minimum 100 feet of #6 copper wire buried no less than eighteen inches deep in the earth and meeting the National Electric Safety Code Rule #094B3

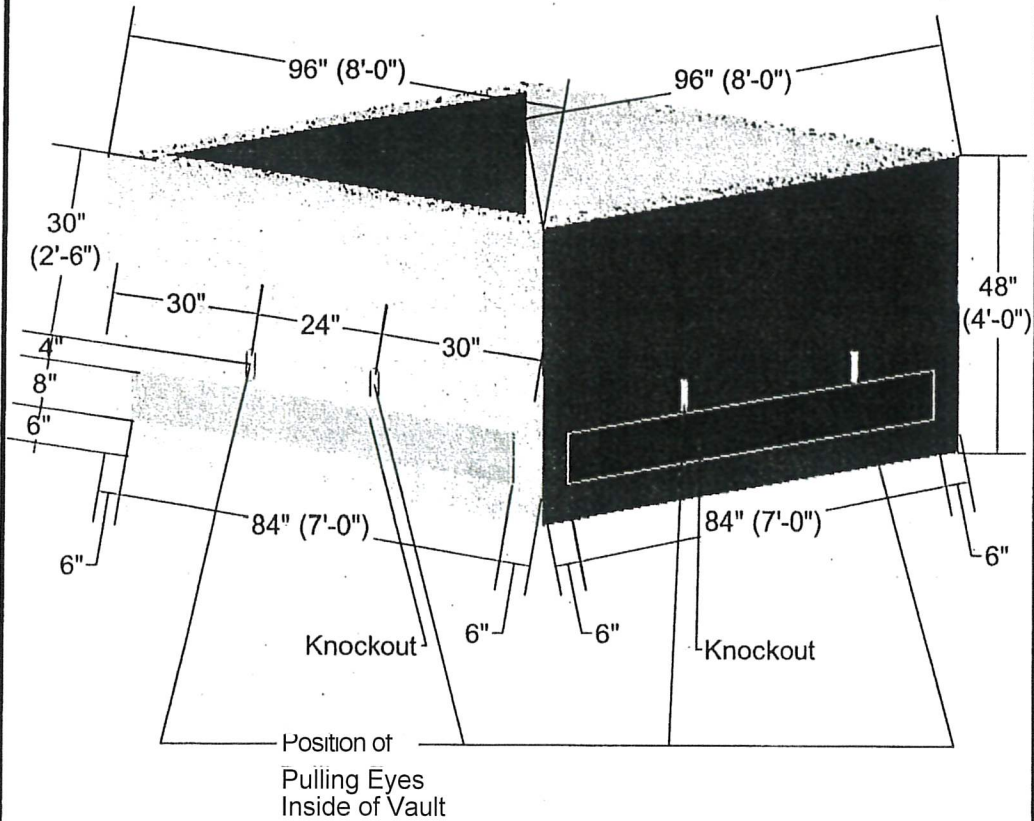

DRAWING: 530-090

Lid for Switchgear

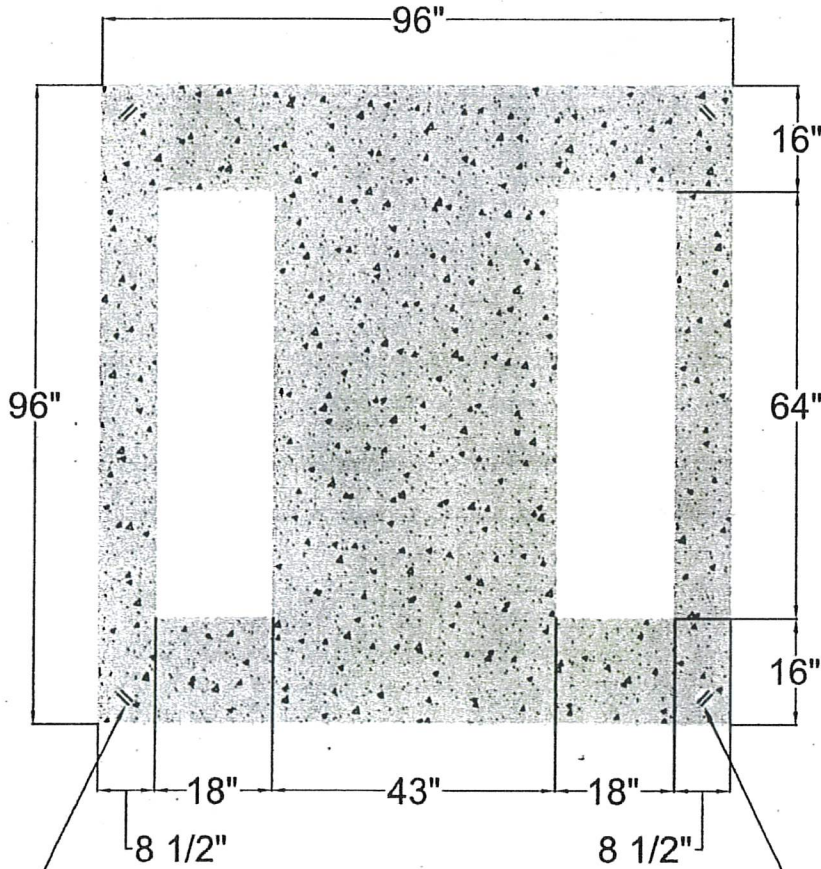

Lifting Eyes to accommodate a chain shall be located at each corner. They shall be flush with the top of the lid.

Lifting Eye Location

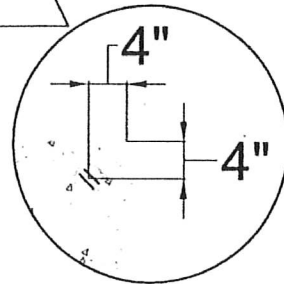

DRAWING: 530-091

Underground Specification

Developer/Applicant
Supplied Material

Date: Feb. 22, 2022
Specification Number: 500-100

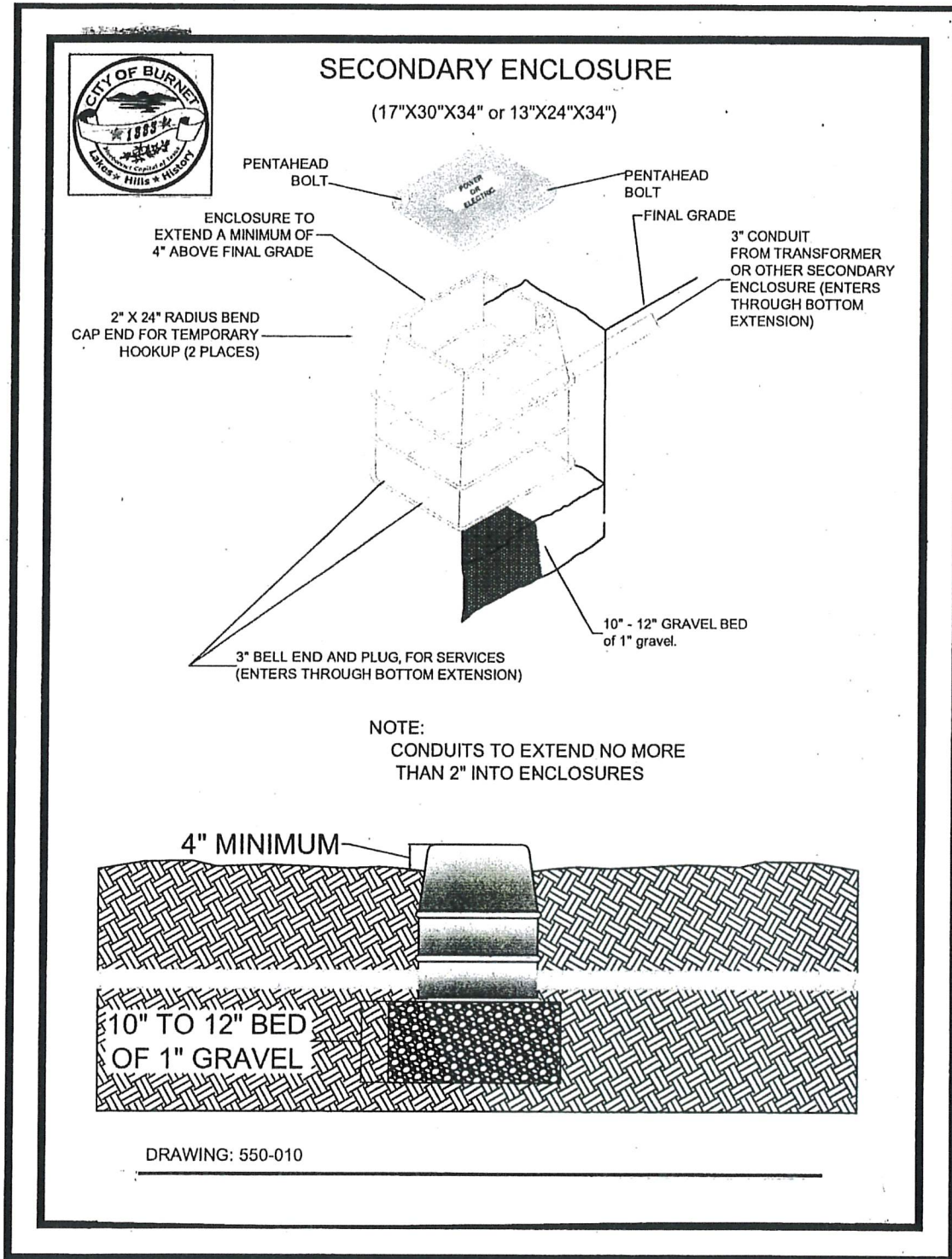

Underground Specification

Developer/Applicant
Supplied Material

Date: Feb. 22, 2022
Specification Number: 500-100

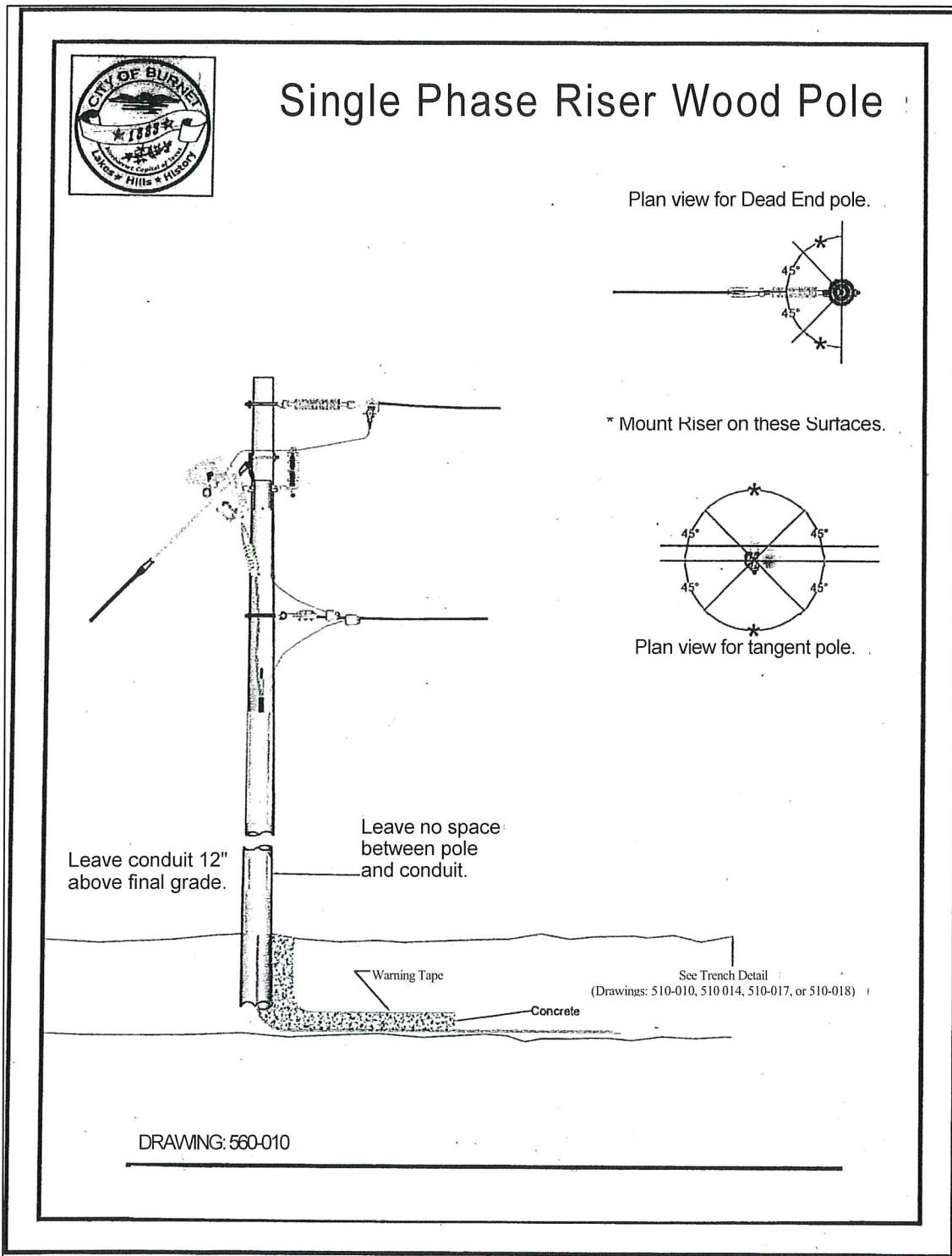



Single Phase Riser Metal Pole using standoff brackets

Plan view for Dead End pole.

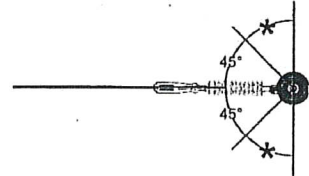

* Mount Riser on these Surfaces.

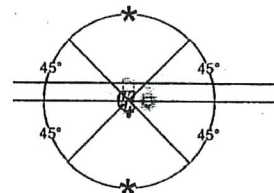

Plan view for tangent pole.

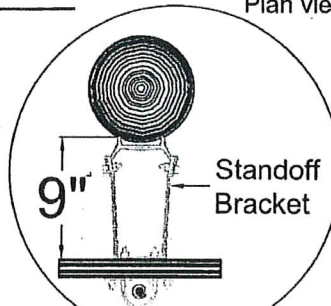
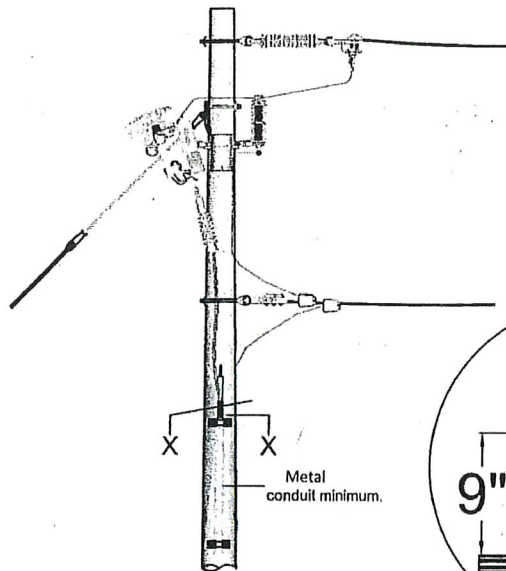

If pole is not at the location leave conduit 12" above final grade.

Warning Tape

Concrete

See Trench Detail
(Drawings: 510-010, 510-014, 510-017, or 510-018)

DRAWING: 560-015

Underground Specification

Developer/Applicant
Supplied Material

Date: Feb. 22, 2022
Specification Number: 500-100

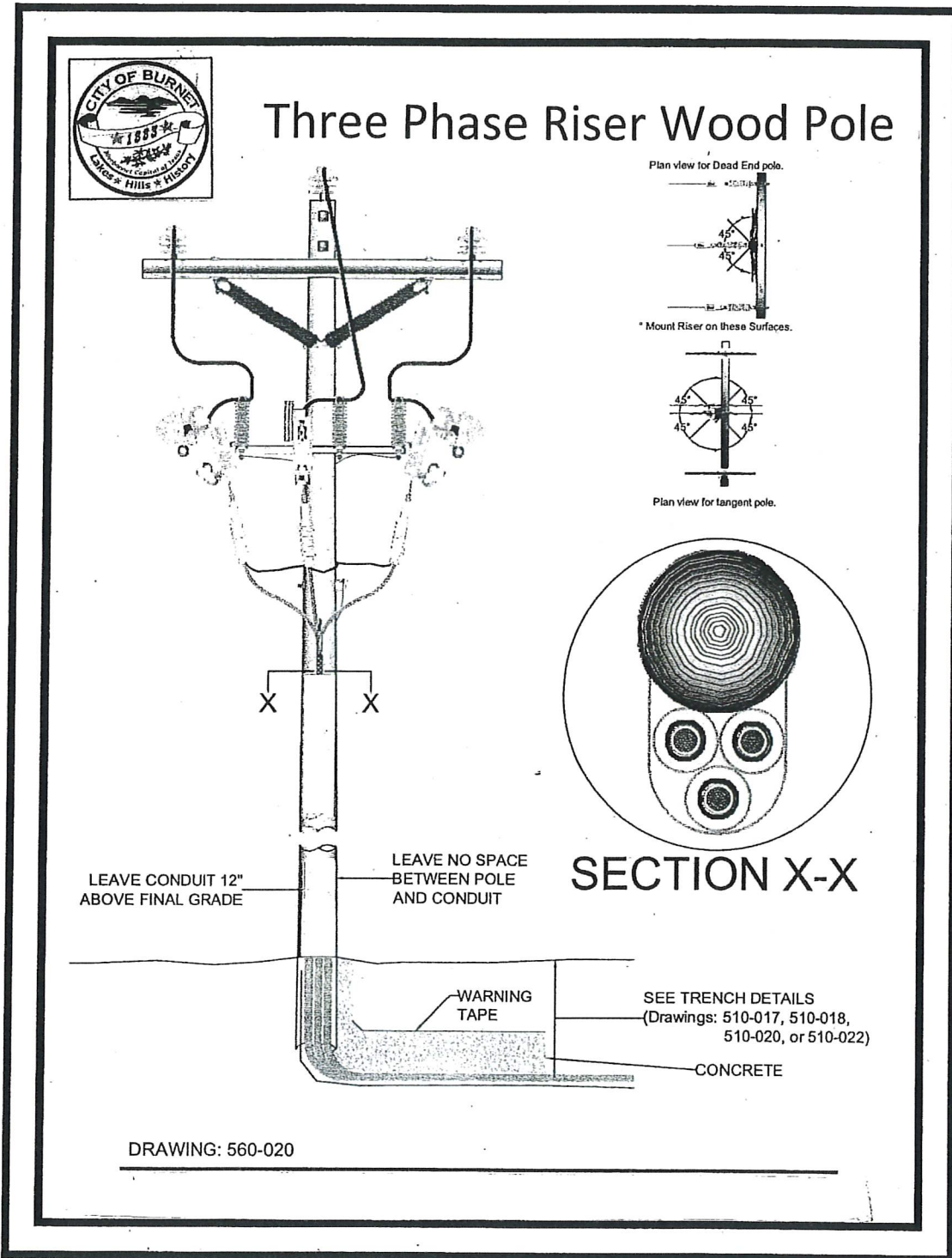



Three Phase Riser Metal Pole using standoff brackets

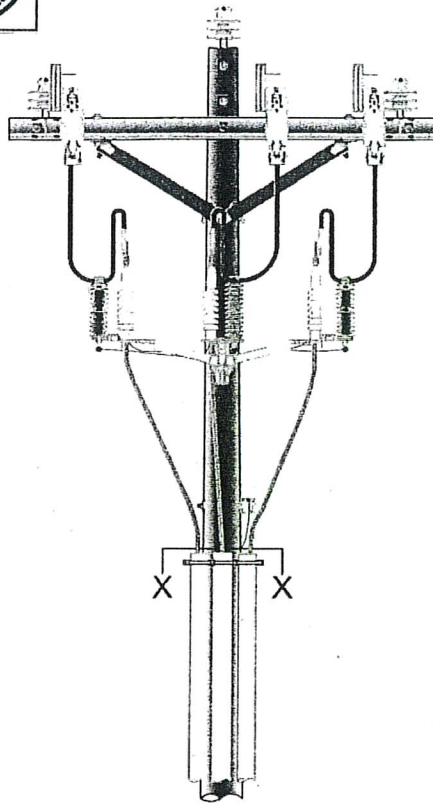

Plan view for Dead End pole.



* Mount Riser on these Surfaces.

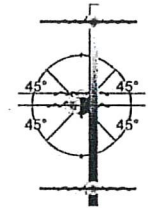

Plan view for tangent pole.

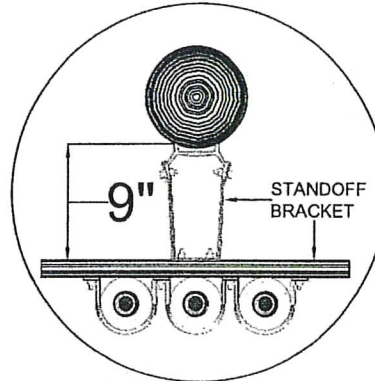

SECTION X-X

If pole is not at the location leave conduit 12" above final grade.

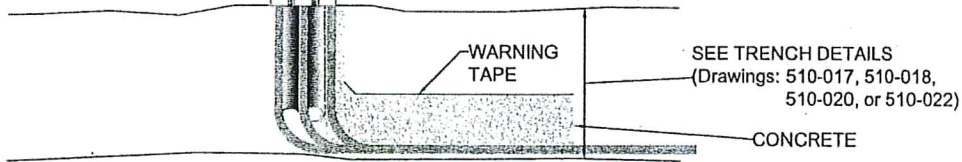

DRAWING: 560-025

Underground Specification

Developer/Applicant
Supplied Material

Date: Feb. 22, 2022
Specification Number: 500-100

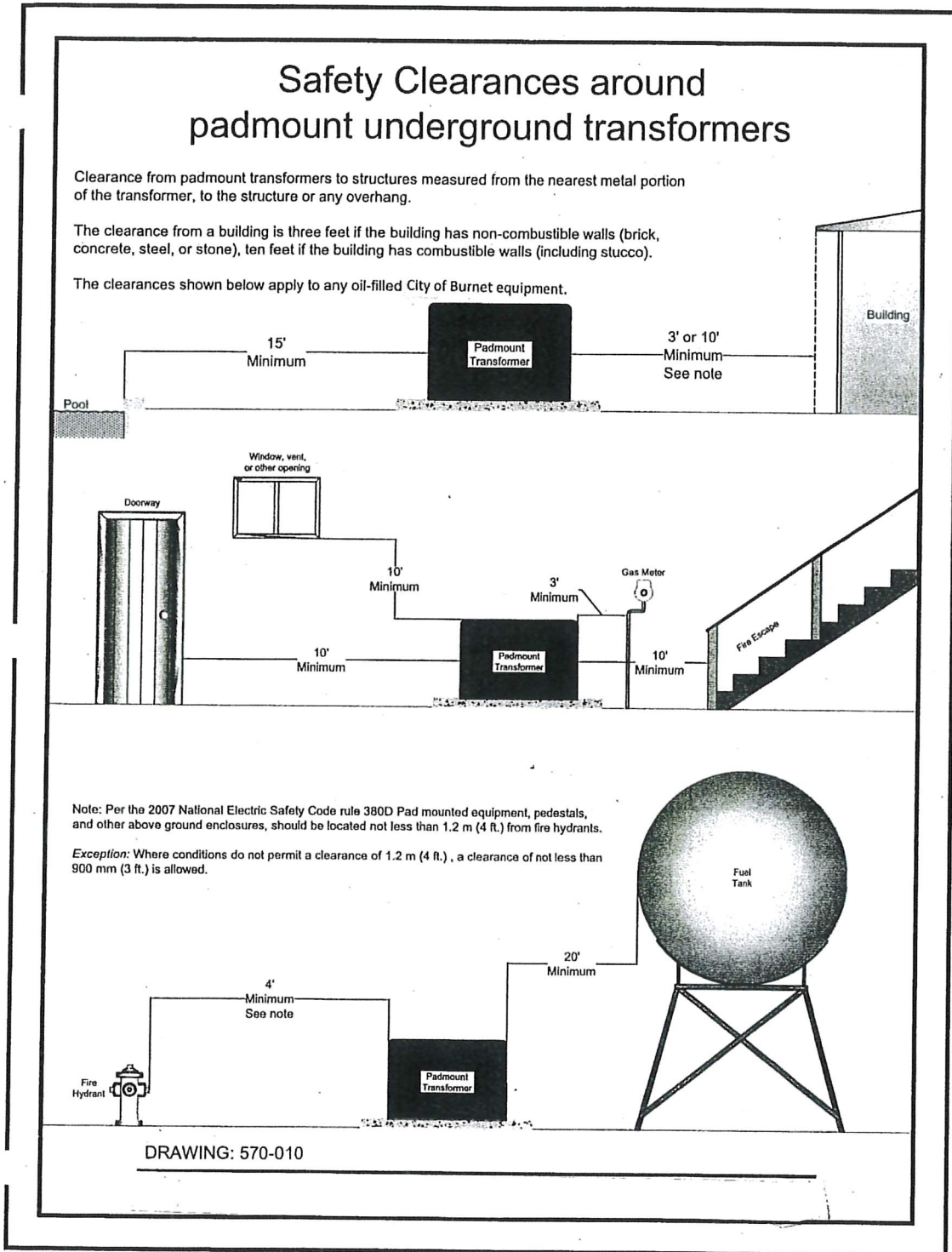

Underground Specification

Developer/Applicant
Supplied Material

Date: Feb. 22, 2022
Specification Number: 500-100

Working Clearances around padmount underground transformers

A minimum clearance of ten feet of clear, level, unobstructed working space is required in front of a padmount transformer, to allow use of hot sticks.

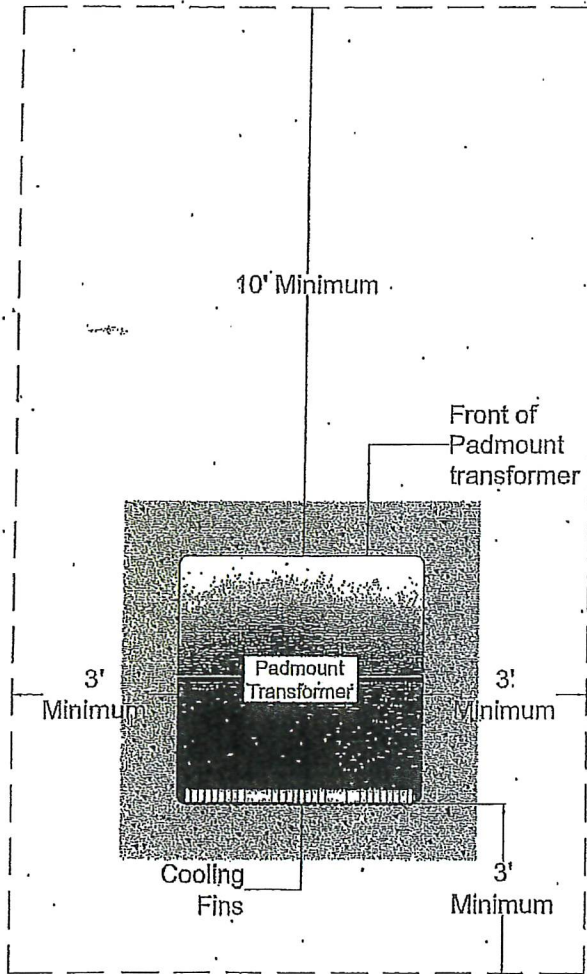

The clearances shown above applies to any oil-filled City of Burnet equipment

DRAWING: 570-015