

# 2023 ROAD REHAB FOG SEAL

RFP 2023-001

PID: CIPTR-2022F



**NOTES:**

1. ALL LOCATIONS SHOWN ARE APPROXIMATE AND BASED ON AERIAL IMAGES. CONTRACTOR SHALL VISIT THE SITE TO BECOME ACQUAINTED WITH THE PROJECT AND ITS LIMITS PRIOR TO BIDDING.
2. CONTRACTOR SHALL NOTIFY THE CITY 48 HOURS PRIOR TO BEGINNING CONSTRUCTION.
3. ALL PAVING INSTALLATIONS SHALL BE SUBJECT TO CITY INSPECTION PRIOR TO THEIR BACKFILL. NO HMAC SHALL BE LAID PRIOR TO CITY INSPECTION.
4. CONTRACTOR SHALL MARK WITH PAINT LIMITS OF STREET REHAB FOR REVIEW & APPROVAL PRIOR TO CITY INSPECTION.
5. ALL CONSTRUCTION ACTIVITIES SHALL BE DONE IN ACCORDANCE TO THE CITY'S TECHNICAL STANDARD MANUAL AND DETAILS.
6. CONSTRUCTION SHALL COMPLY WITH ALL OSHA SAFETY REGULATIONS AND ADDITIONAL MEASURES AS DIRECTED BY THE CITY.
7. WHERE PAVEMENT IS TO BE CUT, THE EXIST. ASPH PVMT SHALL BE SAWCUT, REMOVED, AND REPAVED. ANY ADDITIONAL PVMT DAMAGE CAUSED OUTSIDE SAWCUT LINE AS A RESULT OF CONSTRUCTION ACTIVITIES, SHALL BE SAWCUT, REMOVED, AND REPAVED.
8. REFER TO SPECIFICATIONS AND DETAILS FOR ADDITIONAL NOTES AND INSTRUCTIONS.
9. CONTRACTOR SHALL MAINTAIN TRAFFIC FLOW AT ALL TIMES, VIA FLAGMEN, GUIDE VEHICLES, OR OTHER MEANS AS APPROVED BY THE CITY.
10. CONTRACTOR SHALL PRESENT A TRAFFIC CONTROL PLAN TO THE CITY PRIOR TO CONSTRUCTION.
11. CONTRACTOR SHALL INSTALL VALVE RISERS AND MANHOLE RISERS. THE CITY SHALL SUPPLY THE RISERS MATERIAL, CONTRACTOR TO PERFORM INSTALL DURING PAVING OPERATION. NO SEPARATE PAY APP BUT SUBSIDIARY TO PAVING QUANTITIES.
12. CONTRACTOR SHALL USE A PLATE COMPACTOR TO COMPACTED TAPERED EDGE ON DESIGNATED ROADS.

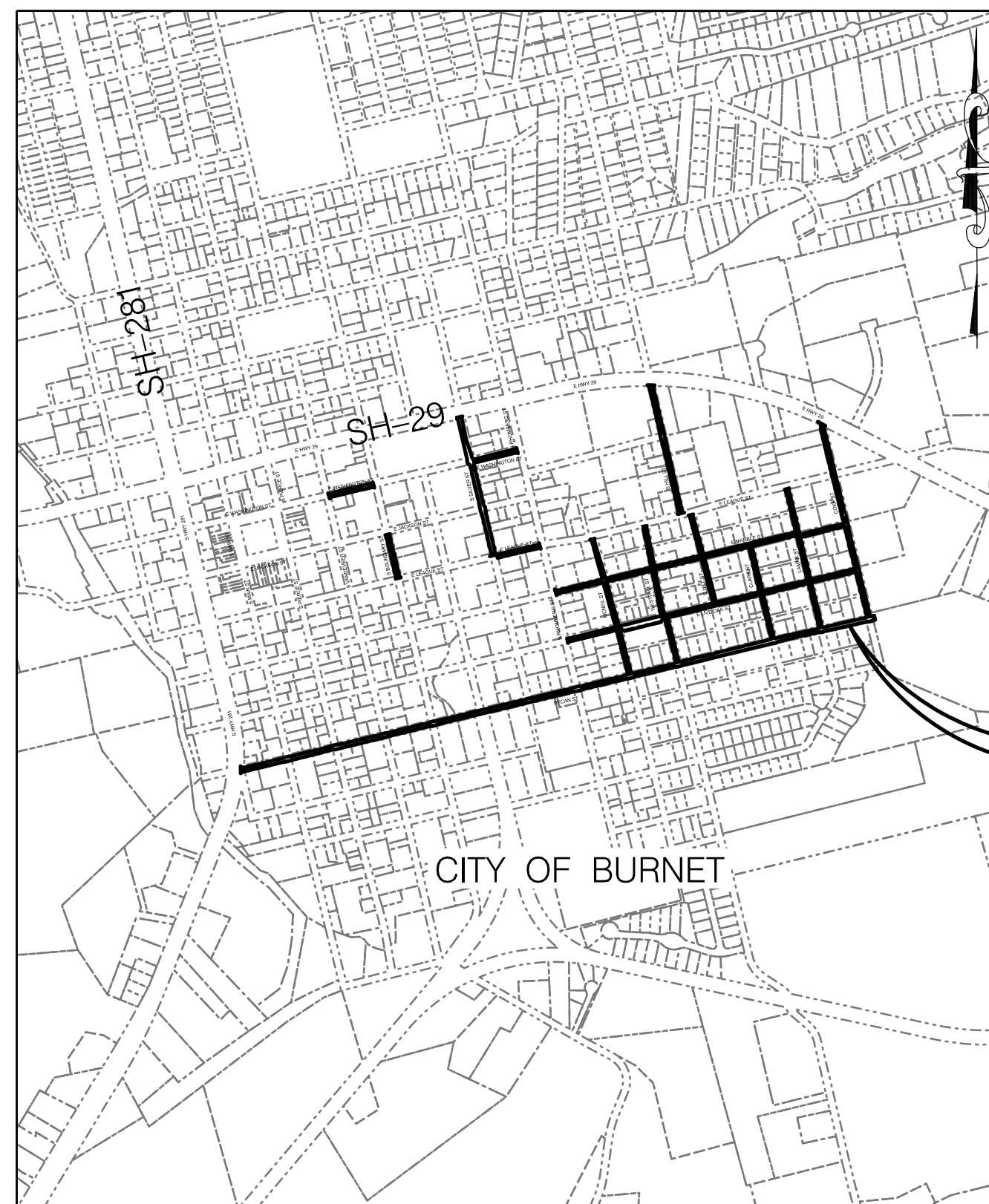

PROJECT

LOCATION MAP  
N.T.S.

SHEET INDEX

C01	COVER SHEET
C02	KEY MAP
C03	PECAN ST
C04	PECAN ST
C05	LAMAR ST
C06	CLARK ST
C07	S HILL ST
C08	WESTFALL ST
C09	MCNEIL ST
C10	COKE ST
C11	S SILVER ST
C12	S BOUNDARY ST
C13	E WASHINGTON ST
C14	E LEAGUE ST
C15	E MARBLE ST
C16	E LIVE OAK ST

TOPOGRAPHIC SURVEY: DRAWINGS AND DESIGN ARE BASED ON AERIAL IMAGE.



C01

1

2

3

4

5

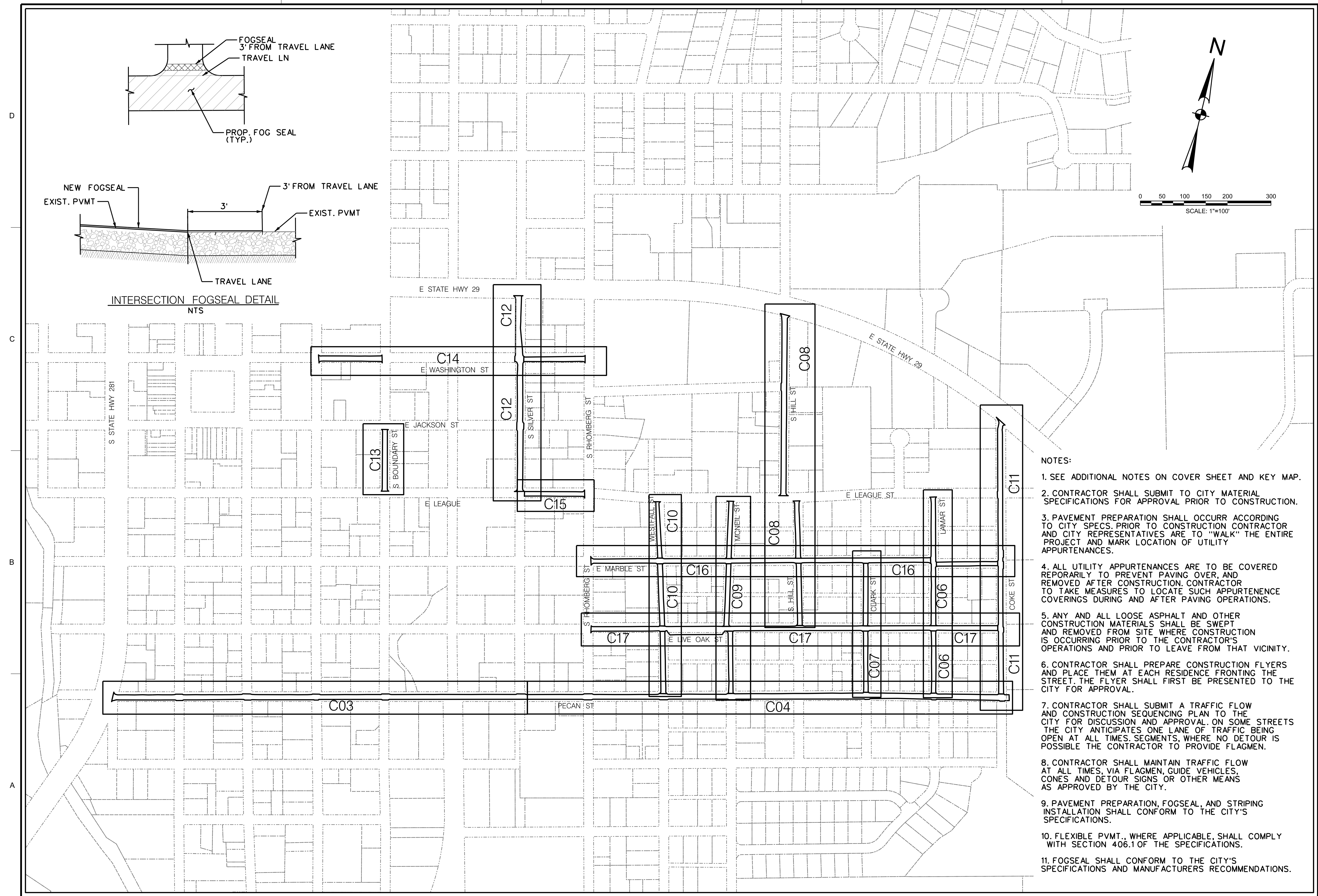
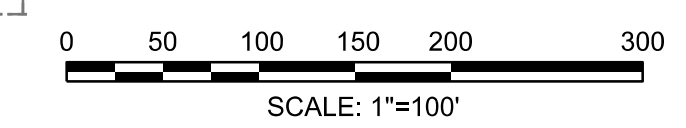
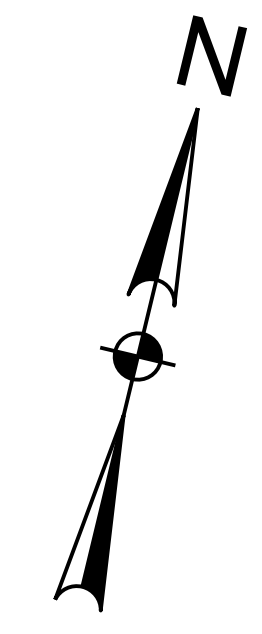
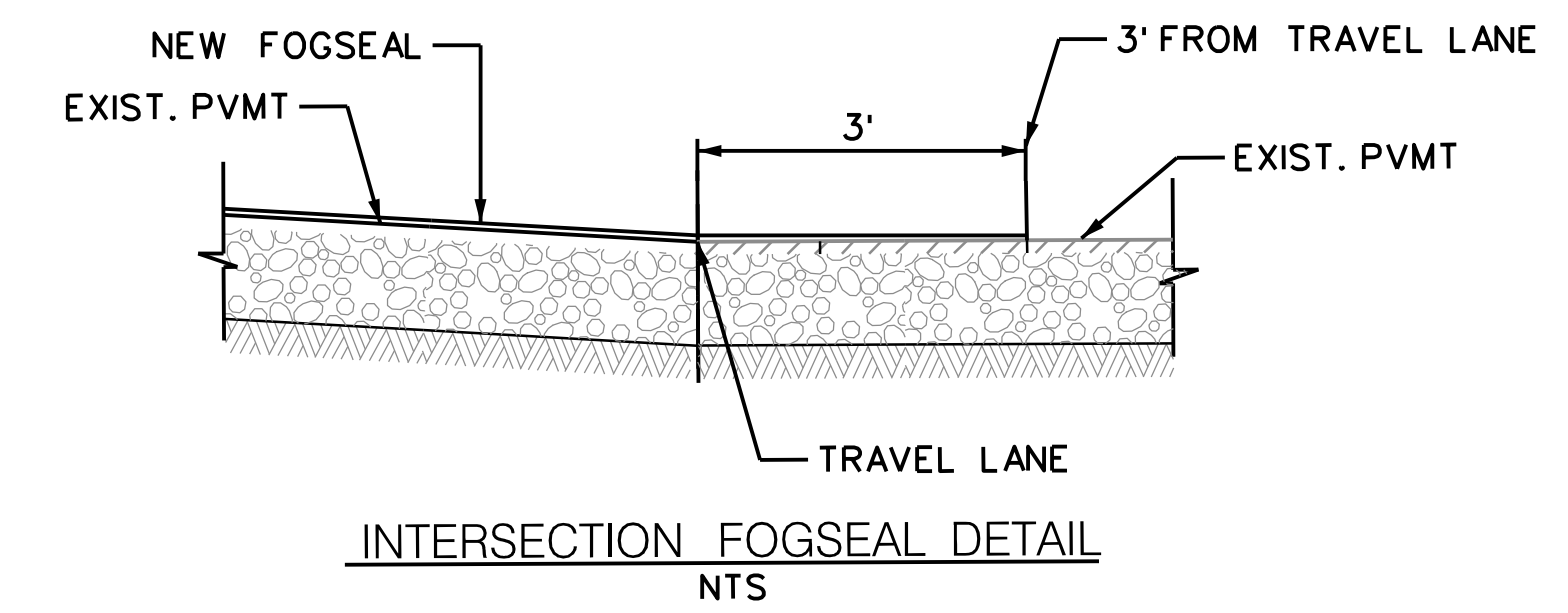
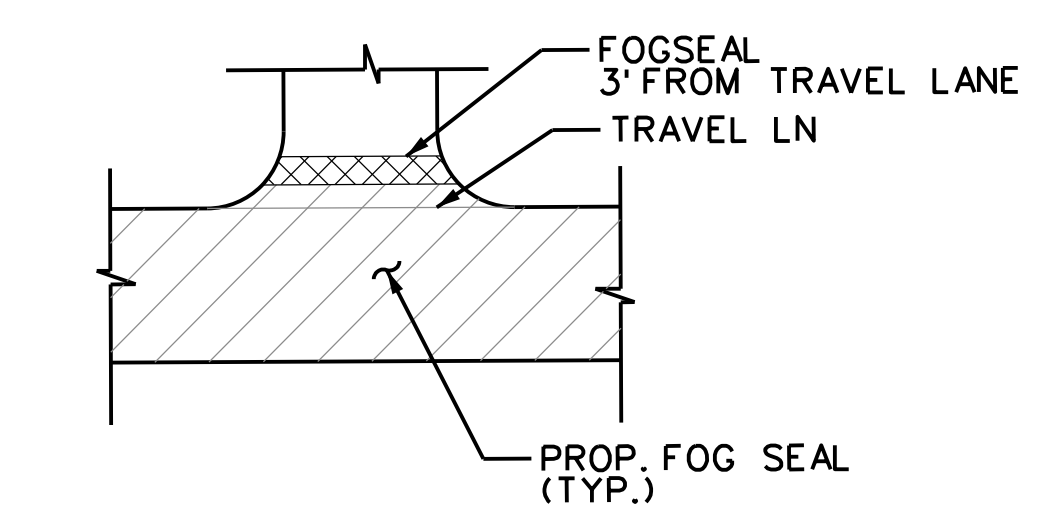

**NOTES:**

1. SEE ADDITIONAL NOTES ON COVER SHEET AND KEY MAP.
2. CONTRACTOR SHALL SUBMIT TO CITY MATERIAL SPECIFICATIONS FOR APPROVAL PRIOR TO CONSTRUCTION.
3. PAVEMENT PREPARATION SHALL OCCUR ACCORDING TO CITY SPECS. PRIOR TO CONSTRUCTION CONTRACTOR AND CITY REPRESENTATIVES ARE TO "WALK" THE ENTIRE PROJECT AND MARK LOCATION OF UTILITY APPURTENANCES.
4. ALL UTILITY APPURTENANCES ARE TO BE COVERED REPAIRABLY TO PREVENT PAVING OVER, AND REMOVED AFTER CONSTRUCTION. CONTRACTOR TO TAKE MEASURES TO LOCATE SUCH APPURTENANCE COVERINGS DURING AND AFTER PAVING OPERATIONS.
5. ANY AND ALL LOOSE ASPHALT AND OTHER CONSTRUCTION MATERIALS SHALL BE SWEEPED AND REMOVED FROM SITE WHERE CONSTRUCTION IS OCCURRING PRIOR TO THE CONTRACTOR'S OPERATIONS AND PRIOR TO LEAVE FROM THAT VICINITY.
6. CONTRACTOR SHALL PREPARE CONSTRUCTION FLYERS AND PLACE THEM AT EACH RESIDENCE FRONTING THE STREET. THE FLYER SHALL FIRST BE PRESENTED TO THE CITY FOR APPROVAL.
7. CONTRACTOR SHALL SUBMIT A TRAFFIC FLOW AND CONSTRUCTION SEQUENCING PLAN TO THE CITY FOR DISCUSSION AND APPROVAL. ON SOME STREETS THE CITY ANTICIPATES ONE LANE OF TRAFFIC BEING OPEN AT ALL TIMES. SEGMENTS, WHERE NO DETOUR IS POSSIBLE THE CONTRACTOR TO PROVIDE FLAGMEN.
8. CONTRACTOR SHALL MAINTAIN TRAFFIC FLOW AT ALL TIMES, VIA FLAGMEN, GUIDE VEHICLES, CONES AND DETOUR SIGNS OR OTHER MEANS AS APPROVED BY THE CITY.
9. PAVEMENT PREPARATION, FOGSEAL, AND STRIPING INSTALLATION SHALL CONFORM TO THE CITY'S SPECIFICATIONS.
10. FLEXIBLE PVMT., WHERE APPLICABLE, SHALL COMPLY WITH SECTION 406.1 OF THE SPECIFICATIONS.
11. FOGSEAL SHALL CONFORM TO THE CITY'S SPECIFICATIONS AND MANUFACTURERS RECOMMENDATIONS.

CITY OF BURNET  
 1001 BUCHANAN DR. SUITE 04  
 BURNET, TX 78611  
 PH: (512) 756-6093

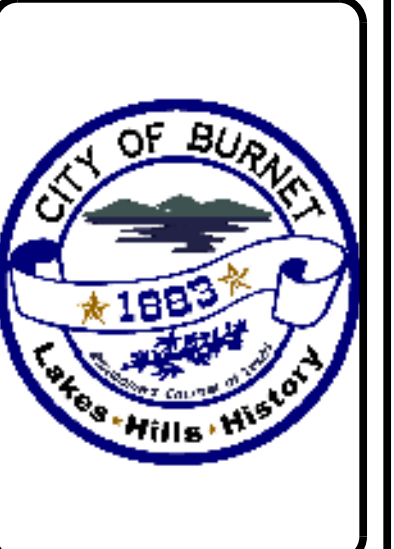

NO.	DESCRIPTION	DATE	ID



2022 STREET REHAB PROGRAM  
**KEY MAP**

SHEET NO.  
**C02**

1

2

3

4

5

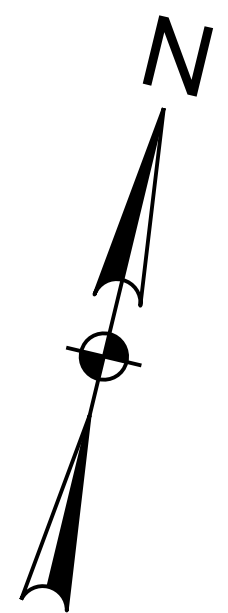
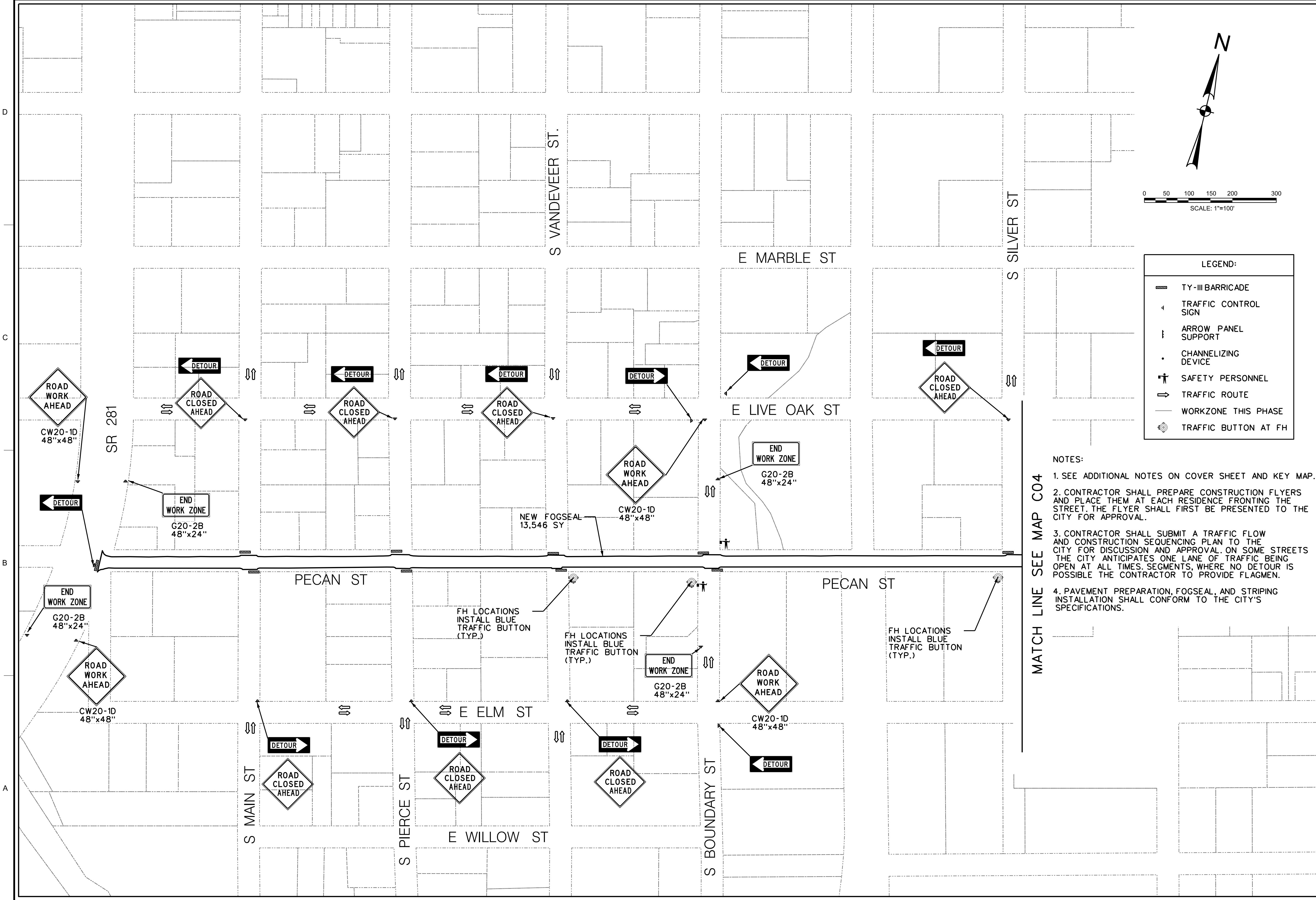

**LEGEND:**

- TY-III BARRICADE
- TRAFFIC CONTROL SIGN
- ARROW PANEL SUPPORT
- CHANNELIZING DEVICE
- SAFETY PERSONNEL
- TRAFFIC ROUTE
- WORKZONE THIS PHASE
- TRAFFIC BUTTON AT FH

- NOTES:**
1. SEE ADDITIONAL NOTES ON COVER SHEET AND KEY MAP.
  2. CONTRACTOR SHALL PREPARE CONSTRUCTION FLYERS AND PLACE THEM AT EACH RESIDENCE FRONTING THE STREET. THE FLYER SHALL FIRST BE PRESENTED TO THE CITY FOR APPROVAL.
  3. CONTRACTOR SHALL SUBMIT A TRAFFIC FLOW AND CONSTRUCTION SEQUENCING PLAN TO THE CITY FOR DISCUSSION AND APPROVAL. ON SOME STREETS THE CITY ANTICIPATES ONE LANE OF TRAFFIC BEING OPEN AT ALL TIMES. SEGMENTS, WHERE NO DETOUR IS POSSIBLE THE CONTRACTOR TO PROVIDE FLAGMEN.
  4. PAVEMENT PREPARATION, FOGSEAL, AND STRIPING INSTALLATION SHALL CONFORM TO THE CITY'S SPECIFICATIONS.

MATCH LINE SEE MAP C04

CITY OF BURNET  
 1001 BUCHANAN DR. SUITE 04  
 BURNET, TX 78611  
 PH: (512) 756-6093

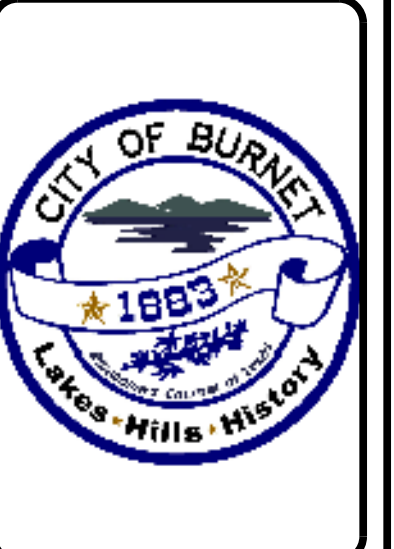

NO.	DESCRIPTION	DATE	ID



2022 STREET REHAB PROGRAM  
**PECAN ST**  
 1 OF 2

SHEET NO.  
**C03**



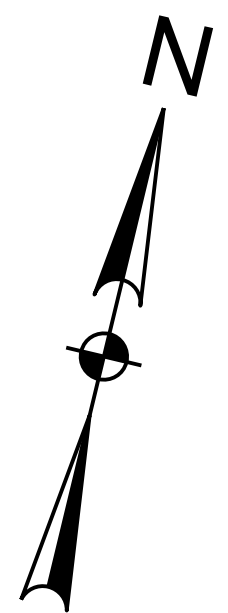
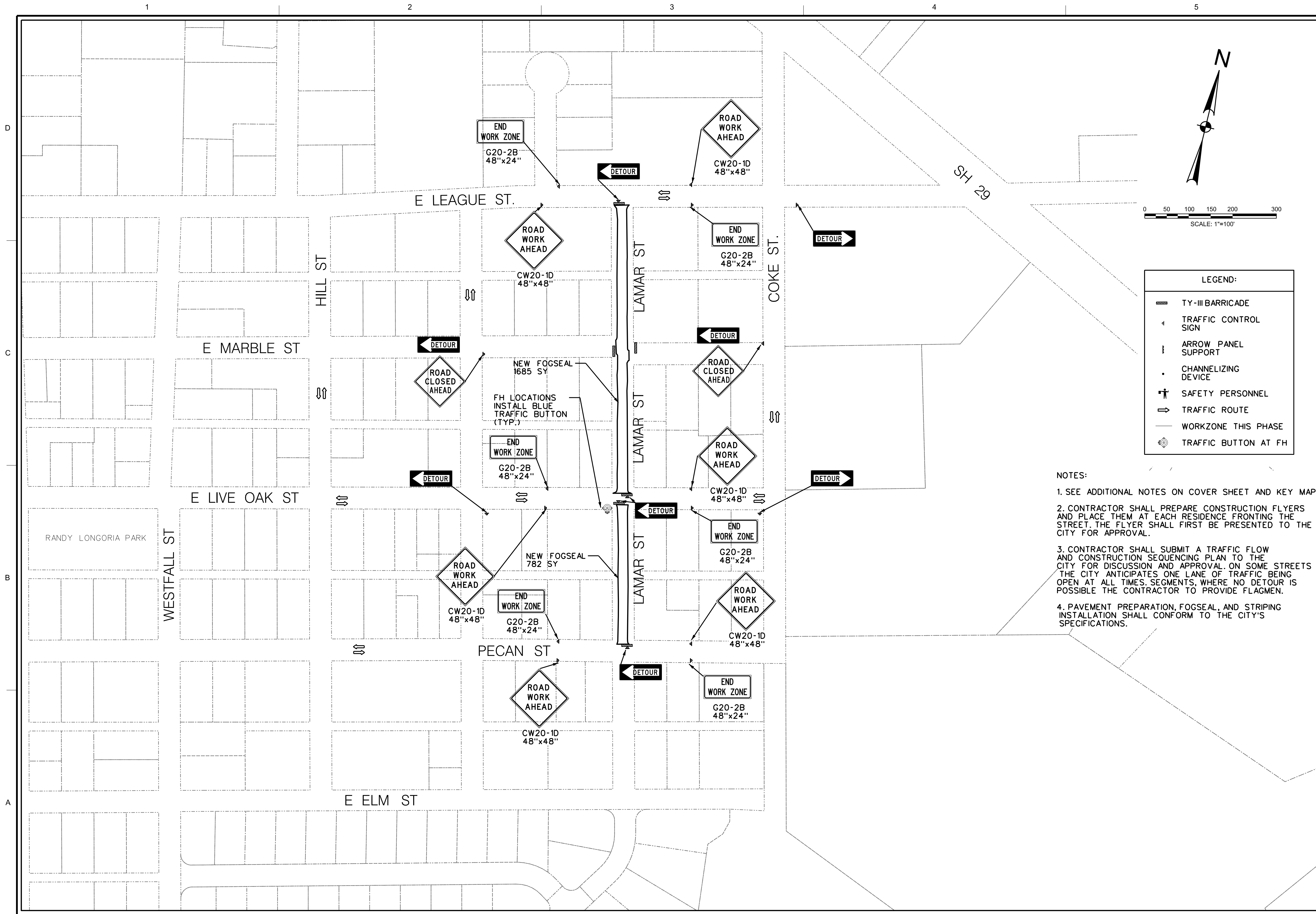

**LEGEND:**

- TY-III BARRICADE
- TRAFFIC CONTROL SIGN
- ARROW PANEL SUPPORT
- CHANNELIZING DEVICE
- SAFETY PERSONNEL
- TRAFFIC ROUTE
- WORKZONE THIS PHASE
- TRAFFIC BUTTON AT FH

- NOTES:**
- SEE ADDITIONAL NOTES ON COVER SHEET AND KEY MAP.
  - CONTRACTOR SHALL PREPARE CONSTRUCTION FLYERS AND PLACE THEM AT EACH RESIDENCE FRONTING THE STREET. THE FLYER SHALL FIRST BE PRESENTED TO THE CITY FOR APPROVAL.
  - CONTRACTOR SHALL SUBMIT A TRAFFIC FLOW AND CONSTRUCTION SEQUENCING PLAN TO THE CITY FOR DISCUSSION AND APPROVAL. ON SOME STREETS THE CITY ANTICIPATES ONE LANE OF TRAFFIC BEING OPEN AT ALL TIMES. SEGMENTS, WHERE NO DETOUR IS POSSIBLE THE CONTRACTOR TO PROVIDE FLAGMEN.
  - PAVEMENT PREPARATION, FOGSEAL, AND STRIPING INSTALLATION SHALL CONFORM TO THE CITY'S SPECIFICATIONS.

CITY OF BURNET  
 1001 BUCHANAN DR. SUITE 04  
 BURNET, TX 78611  
 PH: (512) 756-6093

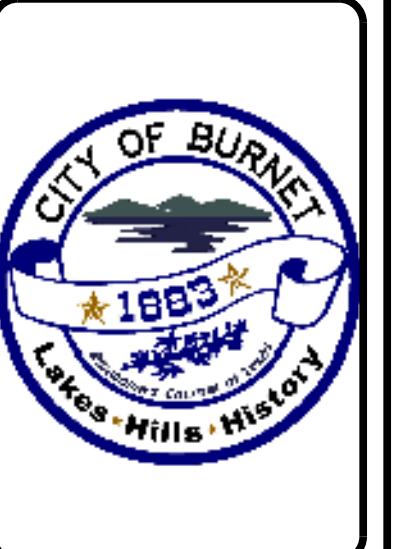

NO.	DESCRIPTION	DATE	ID



2022 STREET REHAB PROGRAM  
**LAMAR ST**

SHEET NO.  
**C05**

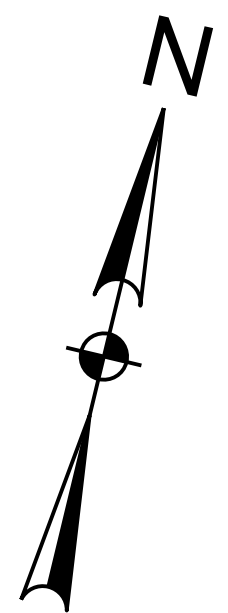
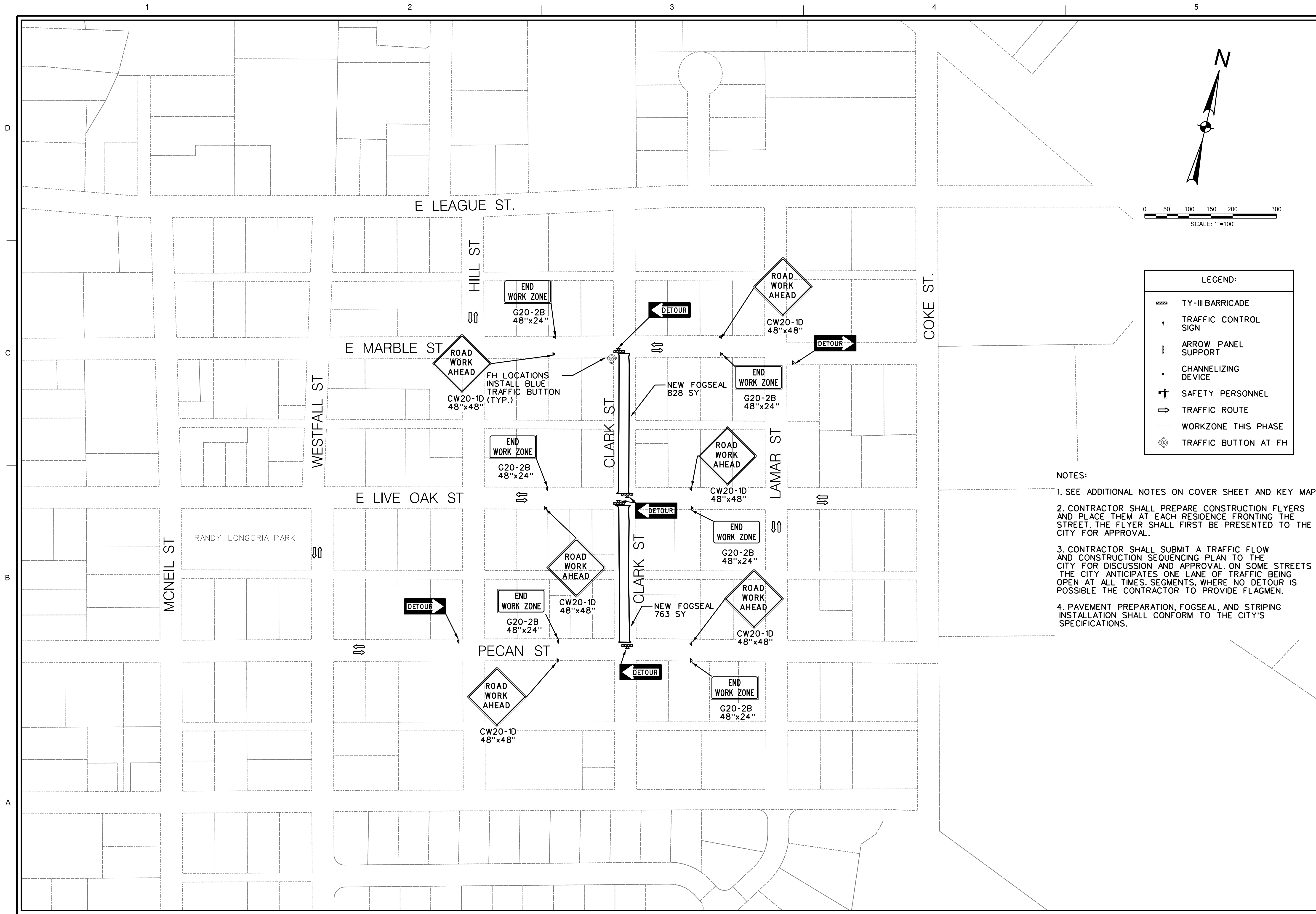

**LEGEND:**

- TY-III BARRICADE
- TRAFFIC CONTROL SIGN
- ARROW PANEL SUPPORT
- CHANNELIZING DEVICE
- SAFETY PERSONNEL
- TRAFFIC ROUTE
- WORKZONE THIS PHASE
- TRAFFIC BUTTON AT FH

- NOTES:**
- SEE ADDITIONAL NOTES ON COVER SHEET AND KEY MAP.
  - CONTRACTOR SHALL PREPARE CONSTRUCTION FLYERS AND PLACE THEM AT EACH RESIDENCE FRONTING THE STREET. THE FLYER SHALL FIRST BE PRESENTED TO THE CITY FOR APPROVAL.
  - CONTRACTOR SHALL SUBMIT A TRAFFIC FLOW AND CONSTRUCTION SEQUENCING PLAN TO THE CITY FOR DISCUSSION AND APPROVAL. ON SOME STREETS THE CITY ANTICIPATES ONE LANE OF TRAFFIC BEING OPEN AT ALL TIMES. SEGMENTS, WHERE NO DETOUR IS POSSIBLE THE CONTRACTOR TO PROVIDE FLAGMEN.
  - PAVEMENT PREPARATION, FOGSEAL, AND STRIPING INSTALLATION SHALL CONFORM TO THE CITY'S SPECIFICATIONS.

CITY OF BURNET  
 1001 BUCHANAN DR. SUITE 04  
 BURNET, TX 78611  
 PH: (512) 756-6093

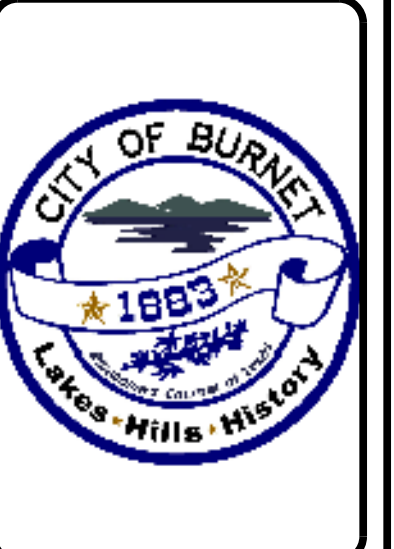

NO.	DESCRIPTION	DATE	ID



2022 STREET REHAB PROGRAM  
**CLARK ST**

SHEET NO.  
**C06**

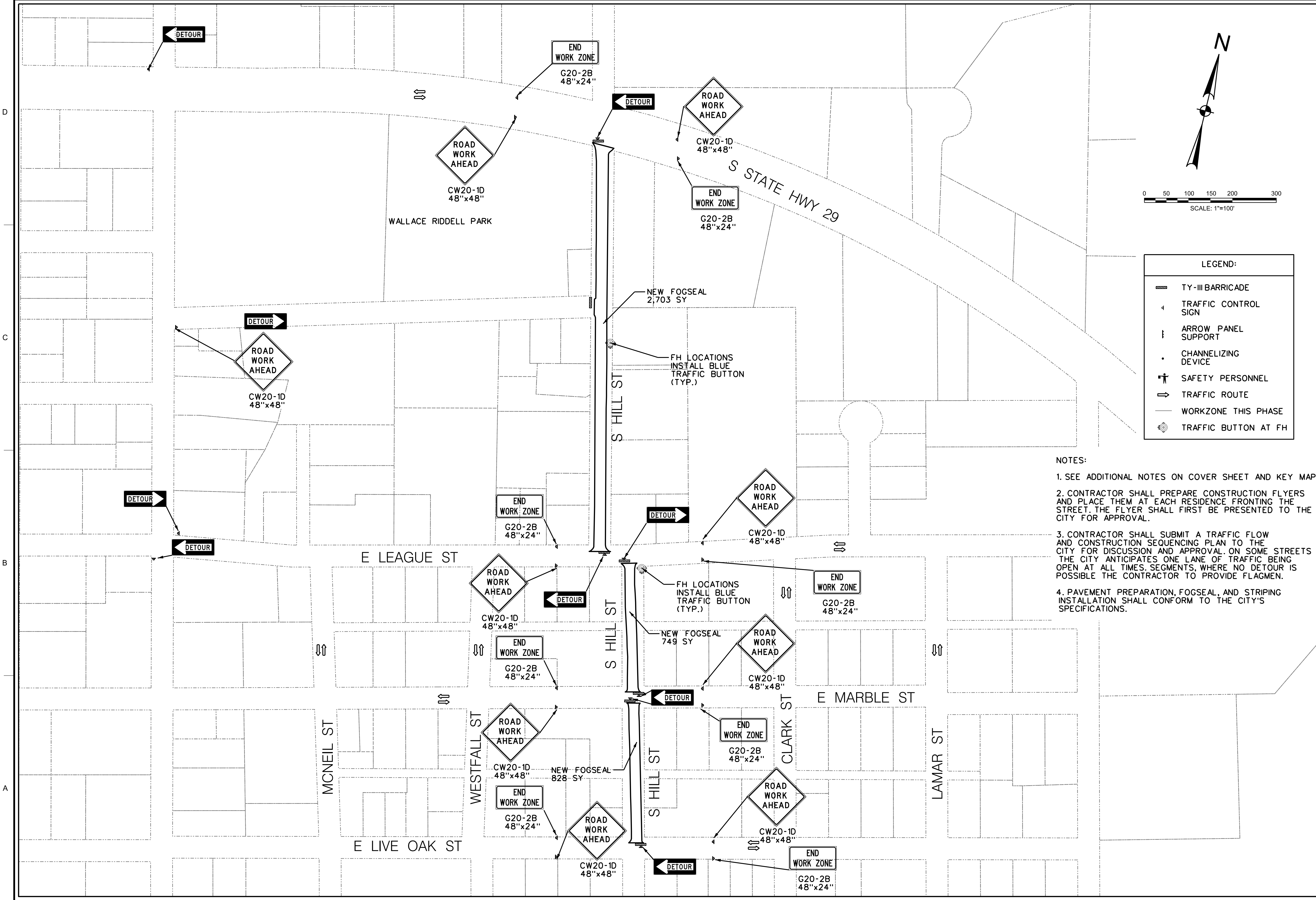

CITY OF BURNET  
 1001 BUCHANAN DR. SUITE 04  
 BURNET, TX 78611  
 PH: (512) 756-6093



NO.	DESCRIPTION	DATE	ID



2022 STREET REHAB PROGRAM  
**S HILL ST**

SHEET NO.  
**C07**

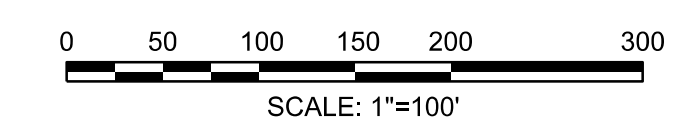
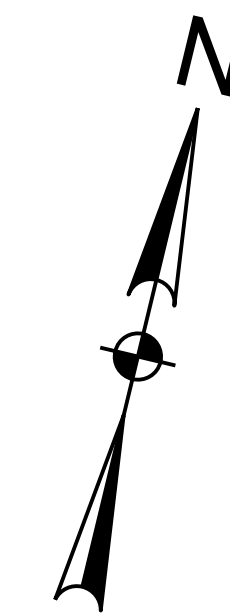

LEGEND:

	TY-III BARRICADE
	TRAFFIC CONTROL SIGN
	ARROW PANEL SUPPORT
	CHANNELIZING DEVICE
	SAFETY PERSONNEL
	TRAFFIC ROUTE
	WORKZONE THIS PHASE
	TRAFFIC BUTTON AT FH

- NOTES:
1. SEE ADDITIONAL NOTES ON COVER SHEET AND KEY MAP.
  2. CONTRACTOR SHALL PREPARE CONSTRUCTION FLYERS AND PLACE THEM AT EACH RESIDENCE FRONTING THE STREET. THE FLYER SHALL FIRST BE PRESENTED TO THE CITY FOR APPROVAL.
  3. CONTRACTOR SHALL SUBMIT A TRAFFIC FLOW AND CONSTRUCTION SEQUENCING PLAN TO THE CITY FOR DISCUSSION AND APPROVAL. ON SOME STREETS THE CITY ANTICIPATES ONE LANE OF TRAFFIC BEING OPEN AT ALL TIMES. SEGMENTS, WHERE NO DETOUR IS POSSIBLE THE CONTRACTOR TO PROVIDE FLAGMEN.
  4. PAVEMENT PREPARATION, FOGSEAL, AND STRIPING INSTALLATION SHALL CONFORM TO THE CITY'S SPECIFICATIONS.

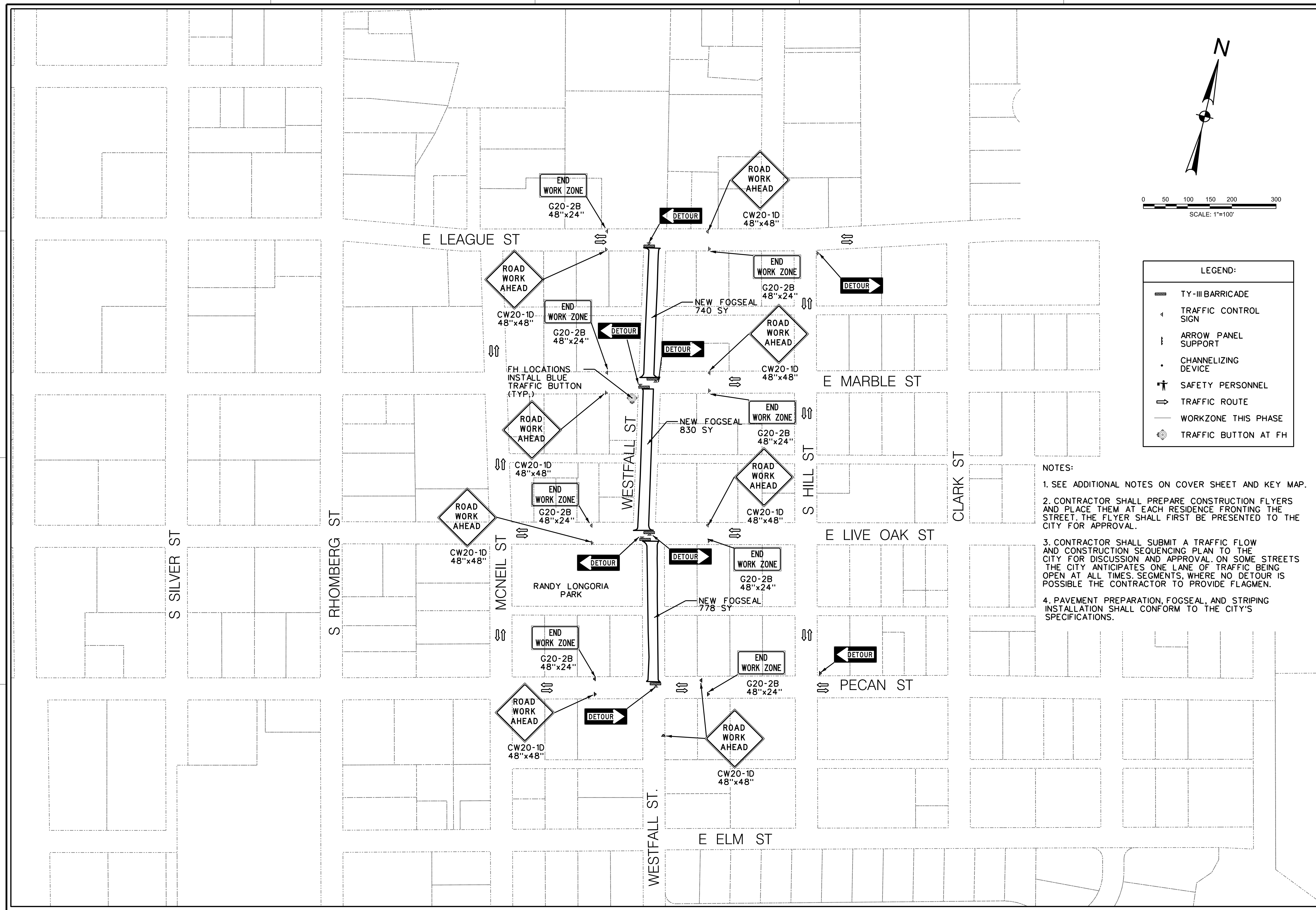

CITY OF BURNET  
 1001 BUCHANAN DR. SUITE 04  
 BURNET, TX 78611  
 PH: (512) 756-6093



NO.	DESCRIPTION	DATE	ID



2022 STREET REHAB PROGRAM  
**WESTFALL ST**

SHEET NO.  
**C08**





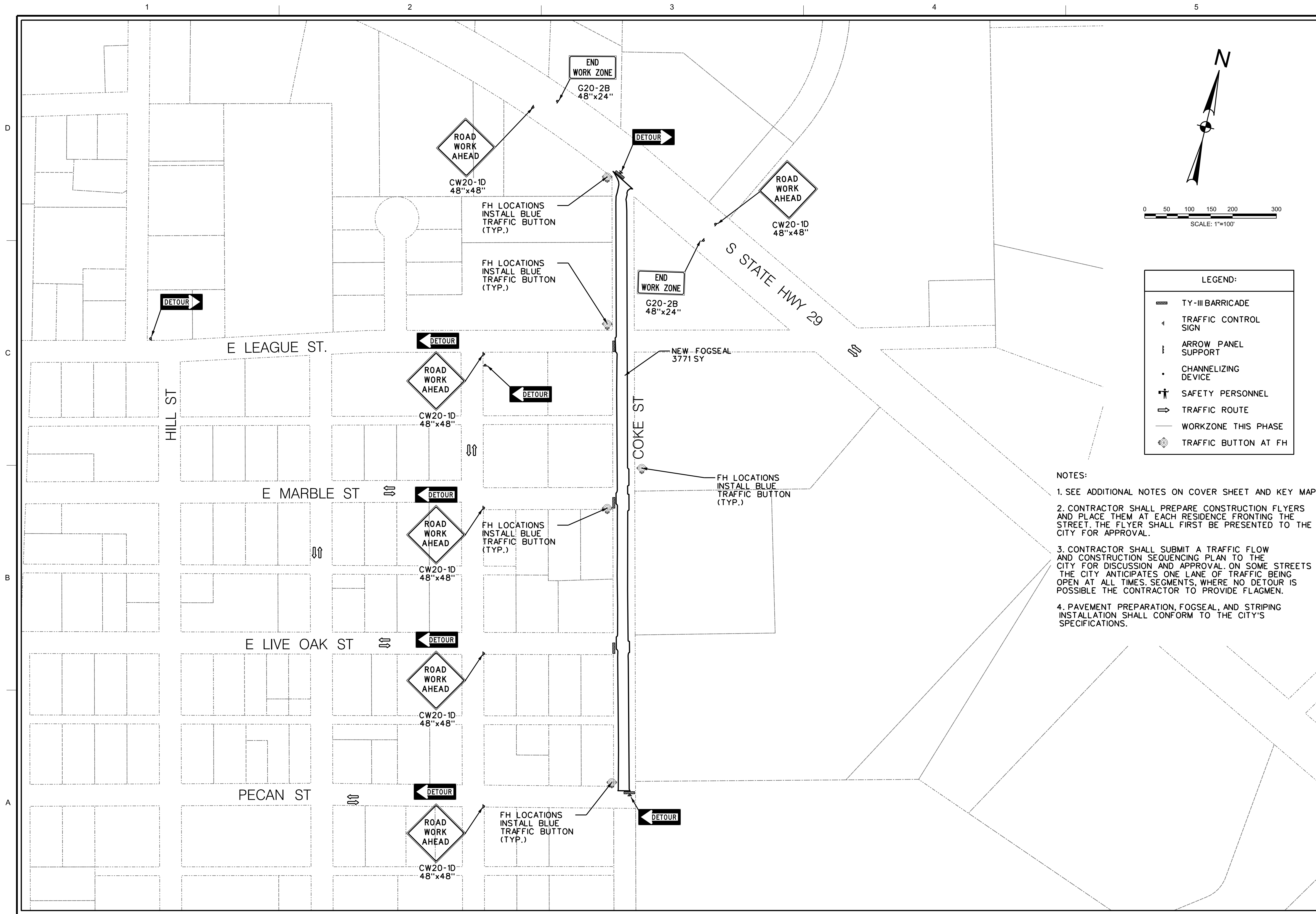

CITY OF BURNET  
 1001 BUCHANAN DR, SUITE 04  
 BURNET, TX 78611  
 PH: (512) 756-6093

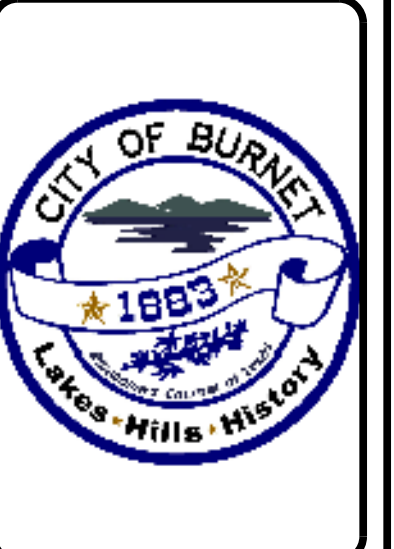

NO.	DESCRIPTION	DATE	ID



2022 STREET REHAB PROGRAM  
**COKE ST**

SHEET NO.  
**C10**

- NOTES:**
- SEE ADDITIONAL NOTES ON COVER SHEET AND KEY MAP.
  - CONTRACTOR SHALL PREPARE CONSTRUCTION FLYERS AND PLACE THEM AT EACH RESIDENCE FRONTING THE STREET. THE FLYER SHALL FIRST BE PRESENTED TO THE CITY FOR APPROVAL.
  - CONTRACTOR SHALL SUBMIT A TRAFFIC FLOW AND CONSTRUCTION SEQUENCING PLAN TO THE CITY FOR DISCUSSION AND APPROVAL. ON SOME STREETS THE CITY ANTICIPATES ONE LANE OF TRAFFIC BEING OPEN AT ALL TIMES. SEGMENTS, WHERE NO DETOUR IS POSSIBLE THE CONTRACTOR TO PROVIDE FLAGMEN.
  - PAVEMENT PREPARATION, FOGSEAL, AND STRIPING INSTALLATION SHALL CONFORM TO THE CITY'S SPECIFICATIONS.



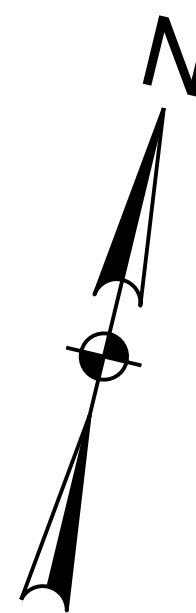
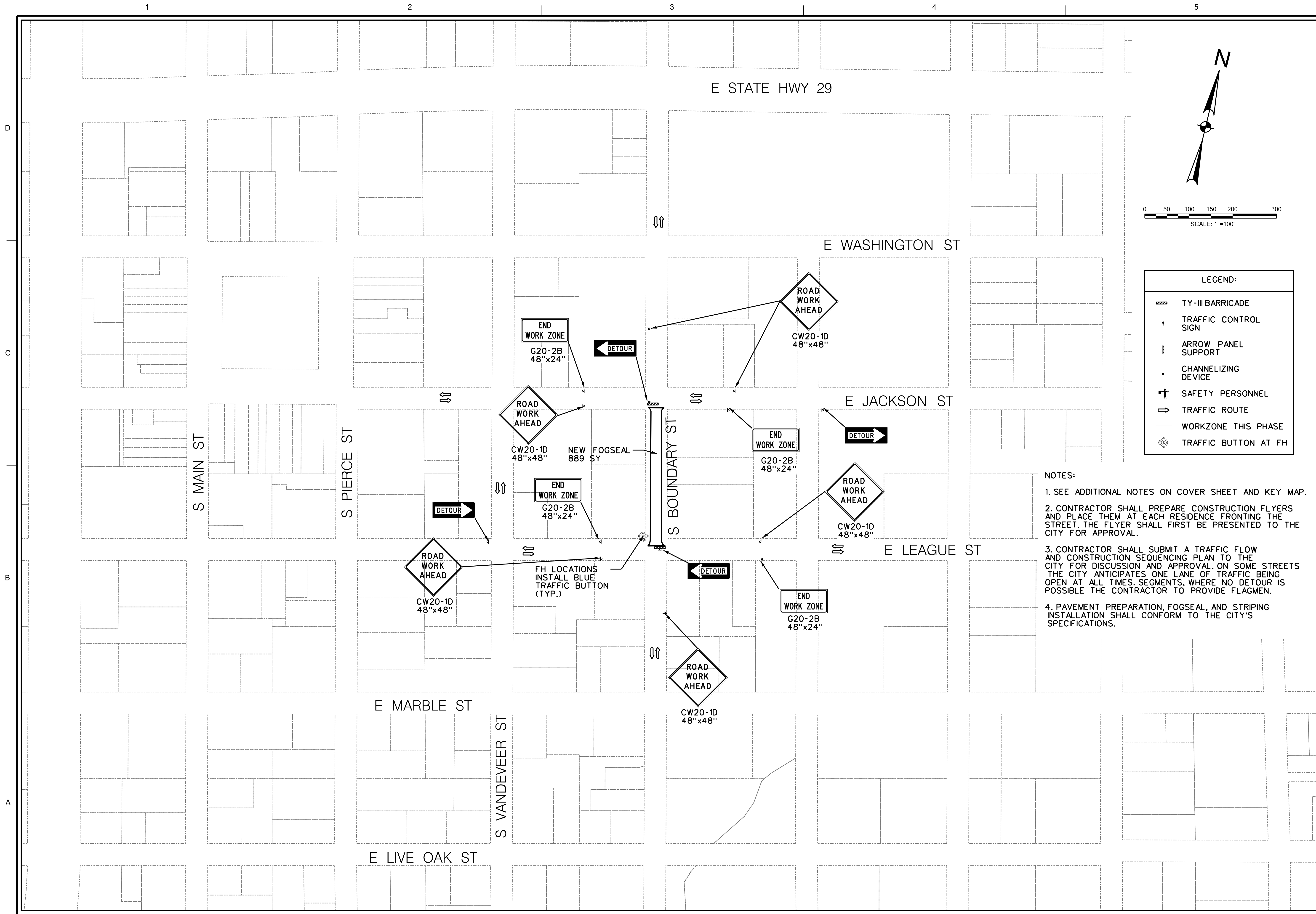

**LEGEND:**

	TY-III BARRICADE
	TRAFFIC CONTROL SIGN
	ARROW PANEL SUPPORT
	CHANNELIZING DEVICE
	SAFETY PERSONNEL
	TRAFFIC ROUTE
	WORKZONE THIS PHASE
	TRAFFIC BUTTON AT FH

- NOTES:**
1. SEE ADDITIONAL NOTES ON COVER SHEET AND KEY MAP.
  2. CONTRACTOR SHALL PREPARE CONSTRUCTION FLYERS AND PLACE THEM AT EACH RESIDENCE FRONTING THE STREET. THE FLYER SHALL FIRST BE PRESENTED TO THE CITY FOR APPROVAL.
  3. CONTRACTOR SHALL SUBMIT A TRAFFIC FLOW AND CONSTRUCTION SEQUENCING PLAN TO THE CITY FOR DISCUSSION AND APPROVAL. ON SOME STREETS THE CITY ANTICIPATES ONE LANE OF TRAFFIC BEING OPEN AT ALL TIMES. SEGMENTS, WHERE NO DETOUR IS POSSIBLE THE CONTRACTOR TO PROVIDE FLAGMEN.
  4. PAVEMENT PREPARATION, FOGSEAL, AND STRIPING INSTALLATION SHALL CONFORM TO THE CITY'S SPECIFICATIONS.

CITY OF BURNET  
 1001 BUCHANAN DR. SUITE 04  
 BURNET, TX 78611  
 PH: (512) 756-6093

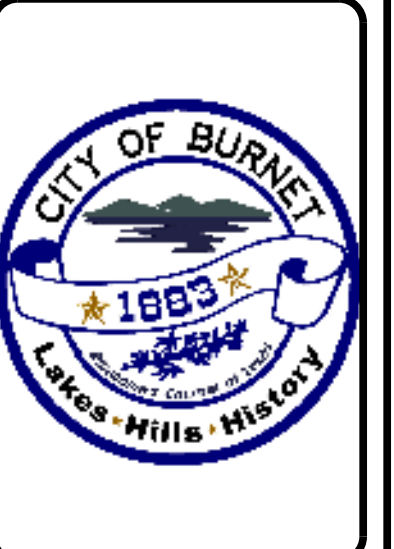

NO.	DESCRIPTION	DATE	ID



2022 STREET REHAB PROGRAM  
**S BOUNDARY ST.**

SHEET NO.  
**C12**



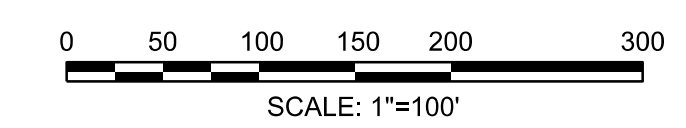
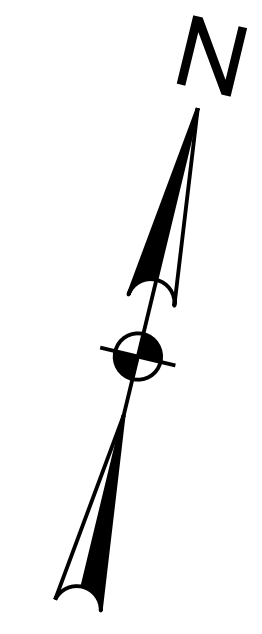
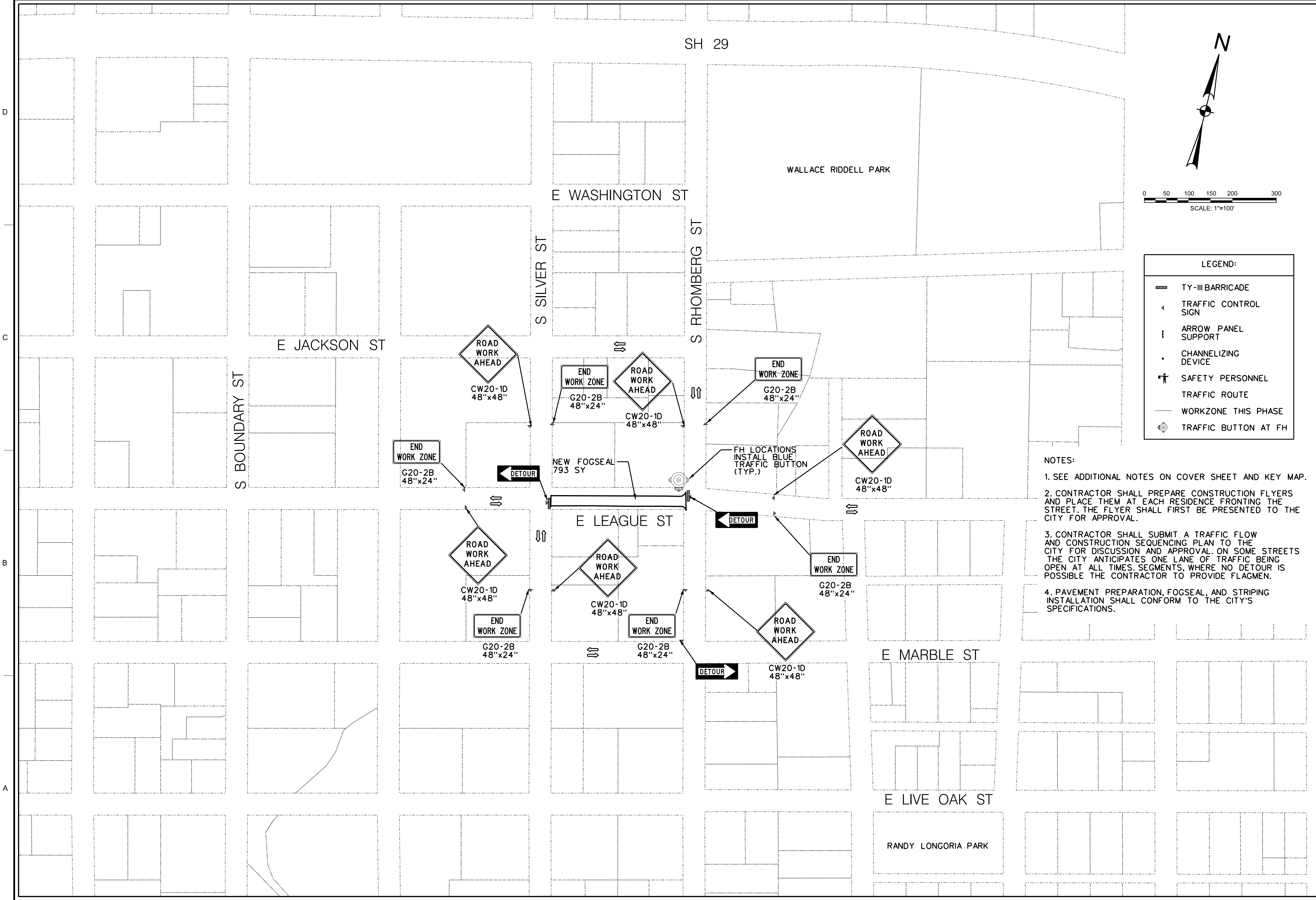

**LEGEND:**

- TY-III BARRICADE
- TRAFFIC CONTROL SIGN
- ARROW PANEL SUPPORT
- CHANNELIZING DEVICE
- SAFETY PERSONNEL
- TRAFFIC ROUTE
- WORKZONE THIS PHASE
- TRAFFIC BUTTON AT FH

- NOTES:**
1. SEE ADDITIONAL NOTES ON COVER SHEET AND KEY MAP.
  2. CONTRACTOR SHALL PREPARE CONSTRUCTION FLYERS AND PLACE THEM AT EACH RESIDENCE FRONTING THE STREET. THE FLYER SHALL FIRST BE PRESENTED TO THE CITY FOR APPROVAL.
  3. CONTRACTOR SHALL SUBMIT A TRAFFIC FLOW AND CONSTRUCTION SEQUENCING PLAN TO THE CITY FOR DISCUSSION AND APPROVAL ON SOME STREETS THE CITY ANTICIPATES ONE LANE OF TRAFFIC BEING OPEN AT ALL TIMES. SEGMENTS, WHERE NO DETOUR IS POSSIBLE THE CONTRACTOR TO PROVIDE FLAGMEN.
  4. PAVEMENT PREPARATION, FOGSEAL, AND STRIPING INSTALLATION SHALL CONFORM TO THE CITY'S SPECIFICATIONS.

CITY OF BURNET  
 1001 BUCHANAN DR. SUITE 04  
 BURNET, TX 78611  
 PH: (512) 756-6093



NO.	DESCRIPTION	DATE	ID



2022 STREET REHAB PROGRAM  
**E LEAGUE ST.**

SHEET NO.  
**C14**



